



Clavinova®

CSP-295GP

CSP-295

CSP-275

CSP-255

Owner's Manual

Mode d'emploi

Manual de instrucciones

Before using the instrument, be sure to read "PRECAUTIONS" on pages 5-6. (CSP-295GP/CSP-275/CSP-255) For information on assembling the instrument, refer to the instructions on page 44 or 48.

Avant d'utiliser l'instrument, lisez attentivement la section « PRÉCAUTIONS D'USAGE » aux pages 5 et 6. (CSP-295GP/CSP-275/CSP-255) Pour plus d'informations sur l'assemblage de l'instrument, reportez-vous aux instructions figurant aux pages 44 ou 48.

Antes de utilizar el instrumento, lea las "PRECAUCIONES", en las páginas 5-6. (CSP-295GP/CSP-275/CSP-255) Para obtener más información sobre el montaje del instrumento, consulte las instrucciones de la página 44 o 48.



Smart Device App "Smart Pianist" (page 24)

You can get even more enjoyment out of this instrument—with additional functions and highly intuitive controls—by connecting to the "Smart Pianist" smart device app.

Application « Smart Pianist » pour appareil intelligent (page 24)

Profitez davantage encore de l'instrument, grâce à des fonctions supplémentaires et des commandes extrêmement intuitives, en vous connectant à l'application « Smart Pianist » pour appareil intelligent.

Aplicación para smartphones o tablets "Smart Pianist" (página 24)

Puede disfrutar aun más este instrumento si lo conecta a la aplicación "Smart Pianist" para smartphones o tablets, que proporciona más funciones y controles muy intuitivos.

English
Français
Español



EN FR ES

FCC INFORMATION (U.S.A.)

1. IMPORTANT NOTICE: DO NOT MODIFY THIS UNIT!

This product, when installed as indicated in the instructions contained in this manual, meets FCC requirements. Modifications not expressly approved by Yamaha may void your authority, granted by the FCC, to use the product.

2. IMPORTANT:

When connecting this product to accessories and/or another product use only high quality shielded cables. Cable/s supplied with this product MUST be used. Follow all installation instructions. Failure to follow instructions could void your FCC authorization to use this product in the USA.

3. NOTE:

This product has been tested and found to comply with the requirements listed in FCC Regulations, Part 15 for Class "B" digital devices. Compliance with these requirements provides a reasonable level of assurance that your use of this product in a residential environment will not result in harmful interference with other electronic devices. This equipment generates/uses radio frequencies and, if not installed and used according to the instructions found in the users manual, may cause interference harmful to the operation of other electronic

devices. Compliance with FCC regulations does not guarantee that interference will not occur in all installations. If this product is found to be the source of interference, which can be determined by turning the unit "OFF" and "ON", please try to eliminate the problem by using one of the following measures:

Relocate either this product or the device that is being affected by the interference.

Utilize power outlets that are on different branch (circuit breaker or fuse) circuits or install AC line filter/s.

In the case of radio or TV interference, relocate/reorient the antenna. If the antenna lead-in is 300 ohm ribbon lead, change the lead-in to co-axial type cable.

If these corrective measures do not produce satisfactory results, please contact the local retailer authorized to distribute this type of product. If you can not locate the appropriate retailer, please contact Yamaha Corporation of America, 6600 Orangethorpe Ave, Buena Park, CA90620

The above statements apply ONLY to those products distributed by Yamaha Corporation of America or its subsidiaries.

* This applies only to products distributed by Yamaha Corporation of America.

(class B)

COMPLIANCE INFORMATION STATEMENT (Supplier's declaration of conformity procedure)

Responsible Party : Yamaha Corporation of America

Address : 6600 Orangethorpe Ave., Buena Park, Calif. 90620

Telephone : 714-522-9011

Type of Equipment : Digital Piano

Model Name : CSP-295GP, CSP-295, CSP-275, CSP-255

This device complies with Part 15 of the FCC Rules.

Operation is subject to the following two conditions:

- 1) this device may not cause harmful interference, and
- 2) this device must accept any interference received including interference that may cause undesired operation.

* This applies only to products distributed by Yamaha Corporation of America.

(FCC SDoC)

The model number, serial number, power requirements, etc., may be found on or near the name plate, which is at the bottom of the unit. You should note this serial number in the space provided below and retain this manual as a permanent record of your purchase to aid identification in the event of theft.

Model No.

Serial No.

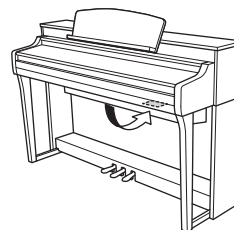

The name plate is located on the bottom of the unit.

(bottom_en_01)



Information for users on collection and disposal of old equipment:

This symbol on the products, packaging, and/or accompanying documents means that used electrical and electronic products should not be mixed with general household waste.

For proper treatment, recovery and recycling of old products, please take them to applicable collection points, in accordance with your national legislation.

By disposing of these products correctly, you will help to save valuable resources and prevent any potential negative effects on human health and the environment which could otherwise arise from inappropriate waste handling.

For more information about collection and recycling of old products, please contact your local municipality, your waste disposal service or the point of sale where you purchased the items.

For business users in the European Union:

If you wish to discard electrical and electronic equipment, please contact your dealer or supplier for further information.

Information on Disposal in other Countries outside the European Union:

This symbol is only valid in the European Union. If you wish to discard these items, please contact your local authorities or dealer and ask for the correct method of disposal.

(weee_eu_en_02)



Informations concernant la collecte et le traitement des déchets d'équipements électriques et électroniques

Le symbole sur les produits, l'emballage et/ou les documents joints signifie que les produits électriques ou électroniques usagés ne doivent pas être mélangés avec les déchets domestiques habituels.

Pour un traitement, une récupération et un recyclage appropriés des déchets d'équipements électriques et électroniques, veuillez les déposer aux points de collecte prévus à cet effet, conformément à la réglementation nationale.

En vous débarrassant correctement des déchets d'équipements électriques et électroniques, vous contribuerez à la sauvegarde de précieuses ressources et à la prévention de potentiels effets négatifs sur la santé humaine qui pourraient advenir lors d'un traitement inapproprié des déchets.

Pour plus d'informations à propos de la collecte et du recyclage des déchets d'équipements électriques et électroniques, veuillez contacter votre municipalité, votre service de traitement des déchets ou le point de vente où vous avez acheté les produits.

Pour les professionnels dans l'Union européenne :

Si vous souhaitez vous débarrasser des déchets d'équipements électriques et électroniques, veuillez contacter votre vendeur ou fournisseur pour plus d'informations.

Informations sur la mise au rebut dans d'autres pays en dehors de l'Union européenne :

Ce symbole est seulement valable dans l'Union européenne. Si vous souhaitez vous débarrasser de déchets d'équipements électriques et électroniques, veuillez contacter les autorités locales ou votre fournisseur et demander la méthode de traitement appropriée.

(weee_eu_fr_02)



Información para usuarios sobre la recogida y eliminación de los equipos antiguos

Este símbolo en los productos, embalajes y documentos anexos significa que los productos eléctricos y electrónicos no deben mezclarse con los desperdicios domésticos normales.

Para el tratamiento, recuperación y reciclaje apropiados de los productos antiguos, llévelos a puntos de reciclaje correspondientes, de acuerdo con la legislación nacional.

Al deshacerse de estos productos de forma correcta, ayudará a ahorrar recursos valiosos y a impedir los posibles efectos desfavorables en la salud humana y en el entorno que de otro modo se producirían si se trataran los desperdicios de modo inapropiado.

Para obtener más información acerca de la recogida y el reciclaje de los productos antiguos, póngase en contacto con las autoridades locales, con el servicio de eliminación de basuras o con el punto de venta donde adquirió los artículos.

Para los usuarios empresariales de la Unión Europea:

Si desea desechar equipos eléctricos y electrónicos, póngase en contacto con su vendedor o proveedor para obtener más información.

Información sobre la eliminación en otros países fuera de la Unión Europea:

Este símbolo solo es válido en la Unión Europea. Si desea desechar estos artículos, póngase en contacto con las autoridades locales o con el vendedor y pregúnteles el método correcto.

(weee_eu_es_02)

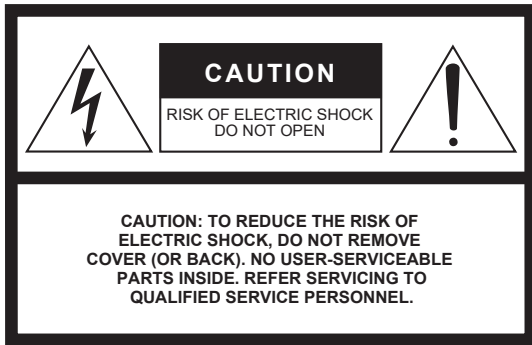

The above warning is located on the bottom of the unit.

Explanation of Graphical Symbols

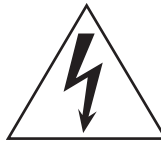

The lightning flash with arrowhead symbol within an equilateral triangle is intended to alert the user to the presence of uninsulated “dangerous voltage” within the product’s enclosure that may be of sufficient magnitude to constitute a risk of electric shock to persons.



The exclamation point within an equilateral triangle is intended to alert the user to the presence of important operating and maintenance (servicing) instructions in the literature accompanying the product.

IMPORTANT SAFETY INSTRUCTIONS

- 1 Read these instructions.
- 2 Keep these instructions.
- 3 Heed all warnings.
- 4 Follow all instructions.
- 5 Do not use this apparatus near water.
- 6 Clean only with dry cloth.
- 7 Do not block any ventilation openings. Install in accordance with the manufacturer’s instructions
- 8 Do not install near any heat sources such as radiators, heat registers, stoves, or other apparatus (including amplifiers) that produce heat.
- 9 Do not defeat the safety purpose of the polarized or grounding-type plug. A polarized plug has two blades with one wider than the other. A grounding type plug has two blades and a third grounding prong. The wide blade or the third prong are provided for your safety. If the provided plug does not fit into your outlet, consult an electrician for replacement of the obsolete outlet.
- 10 Protect the power cord from being walked on or pinched particularly at plugs, convenience receptacles, and the point where they exit from the apparatus.
- 11 Only use attachments/accessories specified by the manufacturer.
- 12 Use only with the cart, stand, tripod, bracket, or table specified by the manufacturer, or sold with the apparatus. When a cart is used, use caution when moving the cart/apparatus combination to avoid injury from tip-over. 
- 13 Unplug this apparatus during lightning storms or when unused for long periods of time.
- 14 Refer all servicing to qualified service personnel. Servicing is required when the apparatus has been damaged in any way, such as power-supply cord or plug is damaged, liquid has been spilled or objects have fallen into the apparatus, the apparatus has been exposed to rain or moisture, does not operate normally, or has been dropped.

WARNING

TO REDUCE THE RISK OF FIRE OR ELECTRIC SHOCK, DO NOT EXPOSE THIS APPARATUS TO RAIN OR MOISTURE.

(UL60065_03)

PRECAUTIONS

PLEASE READ CAREFULLY BEFORE PROCEEDING

Please keep this manual in a safe and handy place for future reference.



WARNING

Always follow the basic precautions listed below to avoid the possibility of serious injury or even death from electrical shock, short-circuiting, damages, fire or other hazards. These precautions include, but are not limited to, the following:

Power supply

- Do not place the power cord near heat sources such as heaters or radiators. Also, do not excessively bend or otherwise damage the cord, or place heavy objects on it.
- Only use the voltage specified as correct for the instrument. The required voltage is printed on the name plate of the instrument.
- Use only the supplied power cord/plug. Do not use the power cord/plug for other devices.
- Check the electric plug periodically and remove any dirt or dust which may have accumulated on it.

Do not open

- This instrument contains no user-serviceable parts. Do not open the instrument or attempt to disassemble or modify the internal components in any way. If it should appear to be malfunctioning, discontinue use immediately and have it inspected by qualified Yamaha service personnel.

Water warning

- Do not expose the instrument to rain, use it near water or in damp or wet conditions, or place on it any containers (such as vases, bottles or glasses) containing liquids which might spill into any openings. If any liquid such as water seeps into the instrument, turn off the power immediately and unplug the power cord from the AC outlet. Then have the instrument inspected by qualified Yamaha service personnel.
- Never insert or remove an electric plug with wet hands.

Fire warning

- Do not put burning items, such as candles, on the unit. A burning item may fall over and cause a fire.

Influences on electro-medical devices

- Radio waves may affect electro-medical devices.
 - Do not use this product near medical devices or inside areas in which the use of radio waves is restricted.
 - Do not use this product within 15 cm (6 in.) of persons with a heart pacemaker or defibrillator implant.

Connections

- Be sure to read the manual of the device to be connected, and follow the instructions. Failure to observe this may cause a fire, overheating, explosion, or malfunction.

Using the bench (If included)

- Do not place the bench in an unstable position where it might accidentally fall over.
- Do not play carelessly with or stand on the bench. Using it as a tool or stepladder or for any other purpose might result in accident or injury.
- Only one person should sit on the bench at a time, in order to prevent the possibility of accident or injury.
- If the bench screws become loose due to extensive long-term use, tighten them periodically using the specified tool in order to prevent the possibility of accident or injury.
- Keep special watch over any small children so that they don't fall off the rear of the bench. Since the bench does not have a backrest, unsupervised use may result in accident or injury.

If you notice any abnormality

- When one of the following problems occur, immediately turn off the power switch and disconnect the electric plug from the outlet. Then have the device inspected by Yamaha service personnel.
 - The power cord or plug becomes frayed or damaged.
 - It emits unusual smells or smoke.
 - Some object has been dropped into the instrument.
 - There is a sudden loss of sound during use of the instrument.
 - If any cracks or breakages exist on the instrument.



CAUTION

Always follow the basic precautions listed below to avoid the possibility of physical injury to you or others, or damage to the instrument or other property. These precautions include, but are not limited to, the following:

Power supply/Power cord

- Do not connect the instrument to an electrical outlet using a multiple-connector. Doing so can result in lower sound quality, or possibly cause overheating in the outlet.
- When removing the electric plug from the instrument or an outlet, always hold the plug itself and not the cord. Pulling by the cord can damage it.
- Remove the electric plug from the outlet when the instrument is not to be used for extended periods of time, or during electrical storms.

Assembly (CSP-295GP/CSP-275/CSP-255)

- Assemble the instrument in the proper sequence by following the assembly instructions in this manual. Also, make sure to tighten the screws regularly. Failure to do so might result in damage to the instrument or even injury.

Location

- Do not place the instrument in an unstable position where it might accidentally fall over.
- Do not go near the instrument during an earthquake. Strong shaking during an earthquake could cause the instrument to move or tip over, resulting in damage to the instrument or its parts, and possibly causing injury.
- (CSP-295GP) Since this product is very heavy, make sure that a sufficient number of people are on hand to help, so you can lift and move it safely and easily. Attempting to lift or move the instrument by force may damage your back, result in other injury, or cause damage to the instrument itself.
- (CSP-295/CSP-275/CSP-255) When transporting or moving the instrument, always use two or more people. Attempting to lift the instrument by yourself may damage your back, result in other injury, or cause damage to the instrument itself.
- Before moving the instrument, remove all connected cables, to prevent damage to the cables or injury to anyone who might trip over them.
- When setting up the product, make sure that the AC outlet you are using is easily accessible. If some trouble or malfunction occurs, immediately turn off the power switch and disconnect the plug from the outlet. Even when the power switch is turned off, electricity is still flowing to the product at the minimum level. When you are not using the product for a long time, make sure to unplug the power cord from the wall AC outlet.

Connections

- Before connecting the instrument to other electronic components, turn off the power for all components. Before turning the power on or off for all components, set all volume levels to minimum.
- Be sure to set the volumes of all components at their minimum levels and gradually raise the volume controls while playing the instrument to set the desired listening level.

Handling

- Do not insert a finger or hand in any gaps on the key cover or instrument. Also take care that the key cover does not pinch your finger.
- Never insert or drop paper, metallic, or other objects into the gaps on the key cover, panel or keyboard. This could cause physical injury to you or others, damage to the instrument or other property, or operational failure.
- (CSP-295) Do not apply excessive force when closing the key cover. A key cover equipped with the SOFT-CLOSE™ mechanism closes the cover slowly. Applying excessive force to the key cover when closing it could damage the SOFT-CLOSE™ mechanism, and possibly result in injury to your hands and fingers caught under the closing key cover.
- Do not rest your weight on, or place heavy objects on the instrument, and do not use excessive force on the buttons, switches or connectors.
- Keep small parts out of the reach of infants. Your children may accidentally swallow them.
- Do not use the instrument/device or headphones for a long period of time at a high or uncomfortable volume level, since this can cause permanent hearing loss. If you experience any hearing loss or ringing in the ears, consult a physician.

Using the bench (If included)

- For benches that can be adjusted, do not adjust the bench height while sitting on the bench, since this can cause excessive force to be imposed on the adjustment mechanism, possibly resulting in damage to the mechanism or even injury.
- Do not place your hand between moving parts. Otherwise, your hand could be pinched between the parts, possibly resulting in injury.

Yamaha cannot be held responsible for damage caused by improper use or modifications to the instrument, or data that is lost or destroyed.

Always turn the power off when the instrument is not in use.

Even when the [] (Standby/On) switch is in standby status (power indicator is off), electricity is still flowing to the instrument at the minimum level.

When you are not using the instrument for a long time, make sure you unplug the power cord from the wall AC outlet.

NOTICE

To avoid the possibility of malfunction/ damage to the product, damage to data, or damage to other property, follow the notices below.

■ Handling

- Do not connect this product to public Wi-Fi and/or Internet directly. Only connect this product to the Internet through a router with strong password-protections. Consult your router manufacturer for information on security best practices.
- Do not use the instrument in the vicinity of a TV, radio, stereo equipment, mobile phone, or other electric devices. Otherwise, the instrument, TV, or radio may generate noise.
- When you use the instrument along with an app on your smart device, such as a smartphone or tablet, we recommend that you enable “Airplane Mode” on the device to avoid noise caused by communication. When turning on airplane mode, Wi-Fi or *Bluetooth*^{*} settings may be turned off. Make sure that the setting is turned on before use.
- Do not expose the instrument to excessive dust or vibrations, or extreme cold or heat (such as in direct sunlight, near a heater, or in a car during the day) to prevent the possibility of disfiguration, damage to the internal components or unstable operation. (Verified operating temperature range: 5° – 40°C, or 41° – 104°F)
- Do not place vinyl, plastic or rubber objects on the instrument, since this might discolor the instrument.
- Do not place objects which can easily be affected by magnetism, such as IC cards, on top of the instrument, since this might damage the objects.
- In the case of a model with a polished finish, bumping the surface of the instrument with metal, porcelain, or other hard objects can cause the finish to crack or peel. Use caution.

■ Maintenance

- When cleaning the instrument, use a soft and dry/slightly damp cloth. Do not use paint thinners, solvents, alcohol, cleaning fluids, or chemical-impregnated wiping cloths.
- In the case of a model with a polished finish, gently remove dust and dirt with a soft cloth. Do not wipe too hard since small particles of dirt can scratch the instrument's finish.
- During extreme changes in temperature or humidity, condensation may occur and water may collect on the surface of the instrument. If water is left, the wooden parts may absorb the water and be damaged. Make sure to wipe any water off immediately with a soft cloth.

■ Saving data

- Some settings of this instrument (page 20) are retained when the power is turned off. However, the saved settings may be lost due to some failure, an operation mistake, etc. Back up your important settings by using the Registration Memory function of the smart device app “Smart Pianist.”

Information

■ About copyrights

- The copyright of the “content”^{*1} installed in this product belongs to Yamaha Corporation or its copyright holder. Except as permitted by copyright laws and other relevant laws, such as copying for personal use, it is prohibited to “reproduce or divert”^{*2} without the permission of the copyright holder. When using the content, consult with a copyright expert.

If you create music or perform with the contents through the original use of the product, and then record and distribute them, the permission of Yamaha Corporation is not required regardless of whether the distribution method is paid or free of charge.

*1: The word “content” includes a computer program, audio data, Accompaniment Style data, MIDI data, waveform data, voice recording data, music score, and score data, etc.

*2: The phrase “reproduce or divert” includes taking out the content itself in this product, or recording and distributing it without changes in a similar manner.

■ About functions/data bundled with the instrument

- Some of the preset songs have been edited for length or arrangement, and may not be exactly the same as the original.
- This device is capable of using various types/formats of music data by optimizing them to the proper format music data for use with the device in advance. As a result, this device may not play them back precisely as their producers or composers originally intended.
- Yamaha may from time to time update firmware of the product without notice for improvement in functions and usability. To take full advantage of this instrument, we recommend that you upgrade your instrument to the latest version. The latest firmware can be downloaded from the website below:
<https://download.yamaha.com/>

■ About this manual

- The illustrations as shown in this manual are for instructional purposes only.
- Unless indicated otherwise, the illustrations as shown in this manual are based on the CSP-275.
- Windows is a registered trademark of Microsoft® Corporation in the United States and other countries.
- Apple, iPhone, iPad and Lightning are trademarks of Apple Inc., registered in the U.S. and other countries.
- App Store is a service mark of Apple Inc., registered in the U.S. and other countries.
- Android and Google Play are trademarks of Google LLC.
- Wi-Fi is a registered trademark of Wi-Fi Alliance®.
- The Bluetooth® word mark and logos are registered trademarks owned by Bluetooth SIG, Inc. and any use of such marks by Yamaha Corporation is under license.
- The company names and product names in this manual are the trademarks or registered trademarks of their respective companies.

■ Tuning

- Unlike an acoustic piano, this instrument does not need to be tuned by an expert (although the pitch can be user-adjusted to match other instruments). This is because the pitch of digital instruments is always maintained perfectly.

■ About disposal

- When disposing of this product, please contact the appropriate local authorities.

■ About Bluetooth®

Bluetooth is a technology for wireless communication between devices within an area of about 10 meters (33 ft.) employing the 2.4 GHz frequency band.

Handling Bluetooth communications

- The 2.4 GHz band used by Bluetooth compatible devices is a radio band shared by many types of equipment. While Bluetooth compatible devices use a technology minimizing the influence of other components using the same radio band, such influence may reduce the speed or distance of communications and in some cases interrupt communications.
- The speed of signal transfer and the distance at which communication is possible differs according to the distance between the communicating devices, the presence of obstacles, radio wave conditions and the type of equipment.
- Yamaha does not guarantee all wireless connections between this unit and devices compatible with Bluetooth function.



Thank you for purchasing this Yamaha Digital Piano!

This instrument gives you the pleasure of playing your favorite songs by yourself with the help of the Stream Lights feature. We recommend that you read this manual carefully so that you can fully take advantage of the advanced and convenient functions of the instrument. We also recommend that you keep this manual in a safe and handy place for future reference.

About the Manuals

This instrument has the following documents and instructional materials.

Included Documents



Owner's Manual (this book)

Explains how to use this instrument.

Online Materials

(Downloadable from the web)



Data List

Contains lists of Voices and Styles, as well as MIDI-related information of this instrument.

To obtain these manuals, access the Yamaha Downloads, enter the model name for searching the desired files.

Yamaha Downloads

<https://download.yamaha.com/>

Included Accessories

- **Owner's Manual (this book) × 1**
- **Online Member Product Registration × 1**
- **Power cord × 1**
- **Bench × 1**
(May not be included depending on your area. Check with your Yamaha dealer.)
- **Headphone hanger × 1, attachment screws × 2**
(See page 22 for instructions.)

When moving and placing the instrument

⚠ CAUTION

When moving the instrument, always hold the bottom of the instrument. Do not hold the key cover or top portion. Improper handling can result in damage to the instrument or personal injury.

NOTICE

Before moving the instrument, rotate the adjuster under the pedal until (page 21) it separates from the floor surface. Contact with the adjuster can result in damage to the floor surface. After moving, be sure to rotate the adjuster until it comes in firm contact with the floor surface.

If you move to another location, you can transport the instrument along with other belongings. Transport the instrument horizontally. Do not lean it up against a wall or stand it up on its side. Do not subject the instrument to excessive vibration or shock.

(CSP-295GP/CSP-275/CSP-255) You can move the instrument as it is (assembled) or disassembled. When transporting the assembled instrument, make sure all screws are properly tightened and have not been loosened by moving the instrument.

(CSP-295) We recommend that you place the instrument away from the wall by about 10 cm to optimize and enhance the overall sound even further.

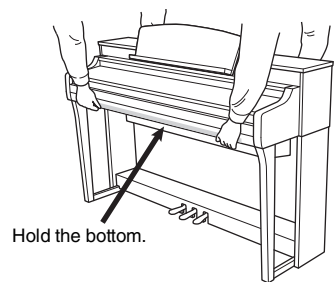

Table of Contents

PRECAUTIONS.....	5	Connections	39
NOTICE.....	7	Listening to Audio data from a Bluetooth-equipped device through this instrument (Bluetooth Audio Function)	39
Information.....	7	Connecting to a computer — [USB-C] terminal	39
About the Manuals.....	8	Connecting to an external audio device	
Included Accessories.....	8	— [AUX IN] jack, AUX OUT [R]/[L/L+R] jacks	40
Main Features – A World of Piano Performance and Control with Smart Pianist –	10	Connecting a footswitch/foot controller	
Panel Controls and Terminals	12	— [AUX PEDAL] jack	41
Starting Up	15	Connecting a microphone or guitar	
Opening/Closing the key cover	15	— [MIC/LINE IN] jack.....	42
Using the music rest.....	16	Connecting external MIDI devices	
Opening/Closing the Lid (CSP-295GP)	18	— MIDI terminals	43
Power supply	19	CSP-295GP Assembly	44
Turning the power on or off	19	CSP-275/CSP-255 Assembly	48
Adjusting the Master Volume	21	Troubleshooting	51
Using the pedals.....	21	Specifications	52
Using headphones	22	Index	55
Playing with Smart Pianist	24		
Installing Smart Pianist to your smart device.....	24		
Connecting with Smart Pianist.....	24		
Connecting wirelessly	25		
Connecting via cables	28		
Playing the Instrument Stand-alone	30		
Function List	30		
Playing with various sounds (Voices).....	32		
Playing back a Song.....	32		
Playing with a Style.....	33		
Using the Metronome.....	34		
Adjusting the tempo.....	34		
Selecting the Reverb type.....	35		
Setting the Touch Sensitivity of the keyboard.....	35		
Transposing the pitch in semitones	36		
Fine-tuning the pitch	36		
Changing the MIDI transmit channel	37		
Turning Audio Loopback on/off.....	37		
Resetting to the Factory-programmed Settings (Initializing).....	38		

Main Features

– A World of Piano Performance and Control with Smart Pianist –

Get more fun out of your piano with Smart Pianist

By using this instrument with the smart device app “Smart Pianist,” you can fully enjoy various functions, such as playing along with a favorite song, or performing with a band or ensemble. Try installing the app to your smart device and connect with this instrument to take advantage of those added features. For connection, refer to page 24.

For details on the app and compatible devices, see the website below or search “Yamaha Smart Pianist” on a web search engine.

<https://www.yamaha.com/kbdapps/>

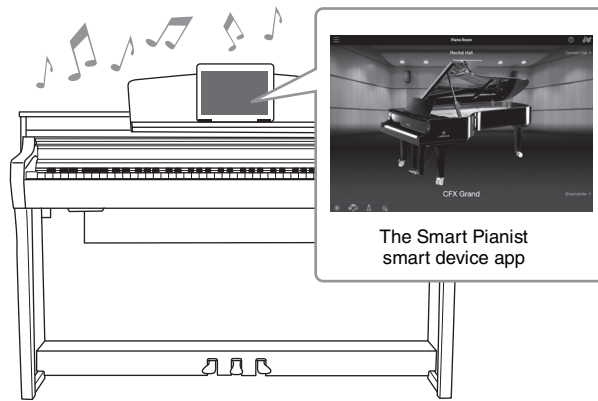

Play your favorite songs right away

A number of songs, including popular, classical and lesson songs, are pre-installed to this instrument. Smart Pianist allows you to view the music notation (score) of these songs. For people who have difficulty reading notation, the Stream Lights function (page 32) shows which key to play next. Just press the keys at the right time as indicated by the moving lights above the keys.

Moreover, by using the Guide function, you can practice at your own pace since Song playback pauses and waits for you to play the correct notes. It also allows you to practice by one-hand, or repeatedly practice a specified range of the song.

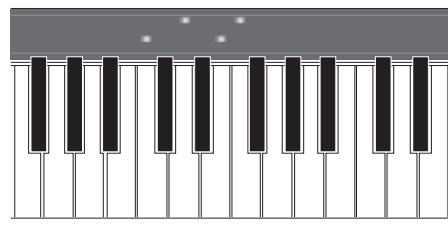
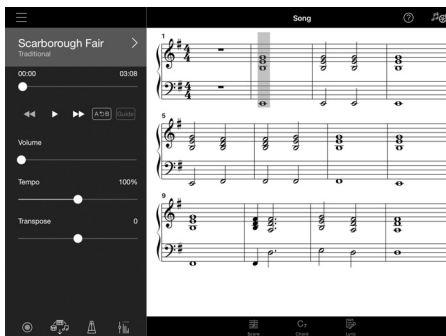

The app also includes an “Audio to Score” function, which automatically creates a piano accompaniment score from songs on your smart device. Even without a score, you can enjoy playing piano accompaniment to a song.

Enjoy backing band accompaniment and singing with your own performance

This instrument features a wide variety of instrumental Voices, including piano, organ, guitar, saxophone and more. It also allows you to layer two Voices, or play different Voices in the right- and left- hand sections. Moreover, the Style function provides dynamic backing band accompaniment, even when you're playing by yourself, and features a wide number of patterns in various genres to match your performance. You can even connect a microphone and sing along with your own performance—and has luxurious harmony functions that allow you to automatically create vocal chorus backing for yourself, even when you're singing alone.

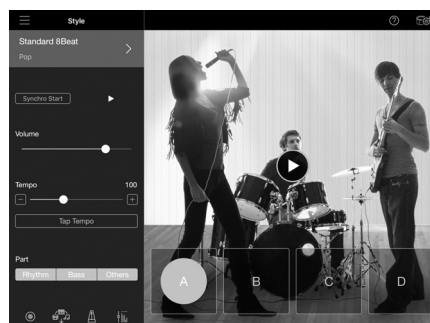
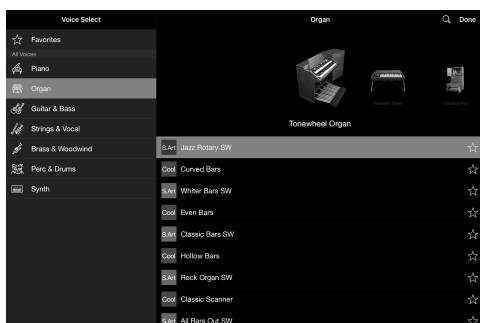

Playing with your favorite piano sound

The piano Voices have been created with samples of Yamaha's flagship CFX concert grand piano and the world renowned Bösendorfer* concert grand piano. On Smart Pianist, the Piano Room function reproduces the way sound echoes based on the environment (such as a concert hall), and the subtle changes in sound due to the opening or closing of the lid of a grand piano—letting you customize the piano sound to your exact liking.

*Bösendorfer is a subsidiary company of Yamaha.

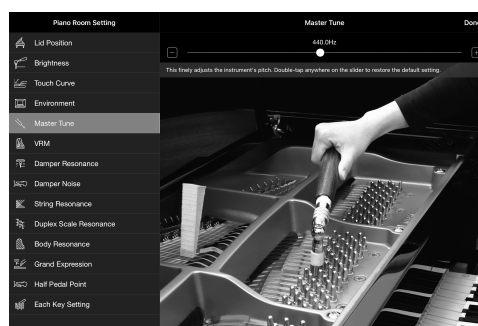
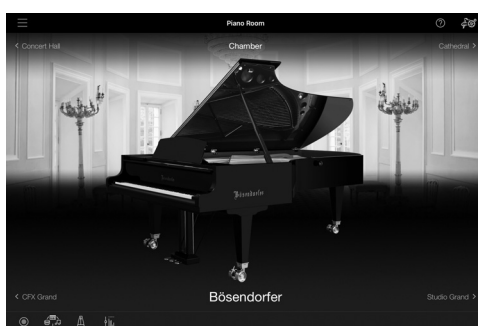

Using Smart Pianist gives you access to many more convenient and powerful functions—such as recording, adjusting volume balance among the keyboard parts/Song/Style, and transposing the pitch of the Song. See page 54 for these additional functions.

NOTE

All screen examples shown here have been captured from the app with the latest specifications as of the publishing date. The screens and the specifications may be updated for improvement.

Panel Controls and Terminals

■ CSP-295GP

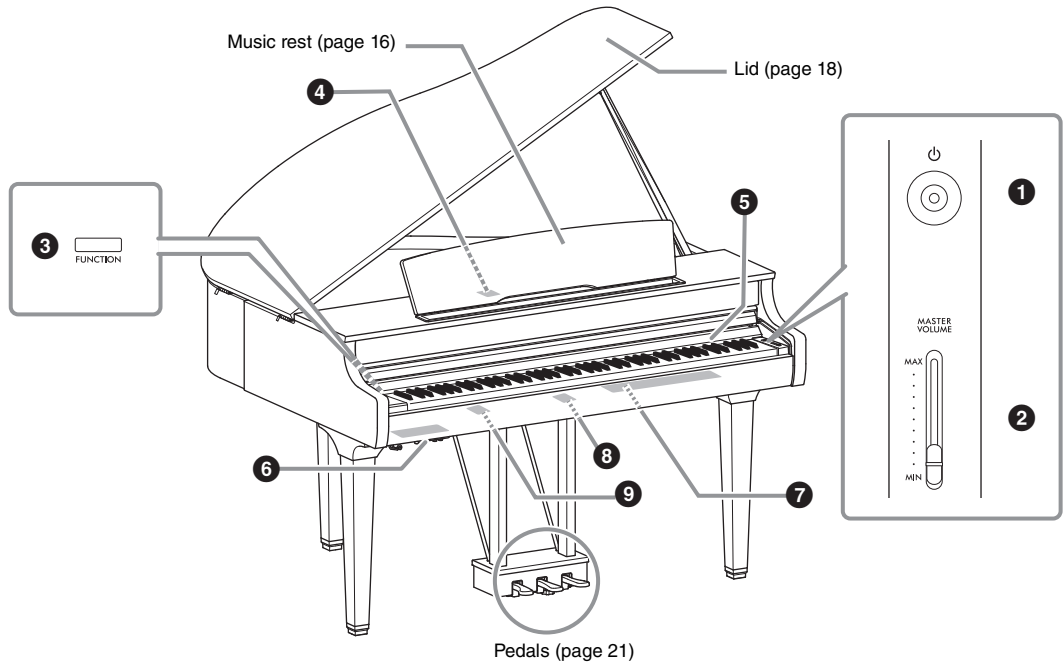

■ CSP-295/CSP-275/CSP-255

This illustration shows the CSP-275.

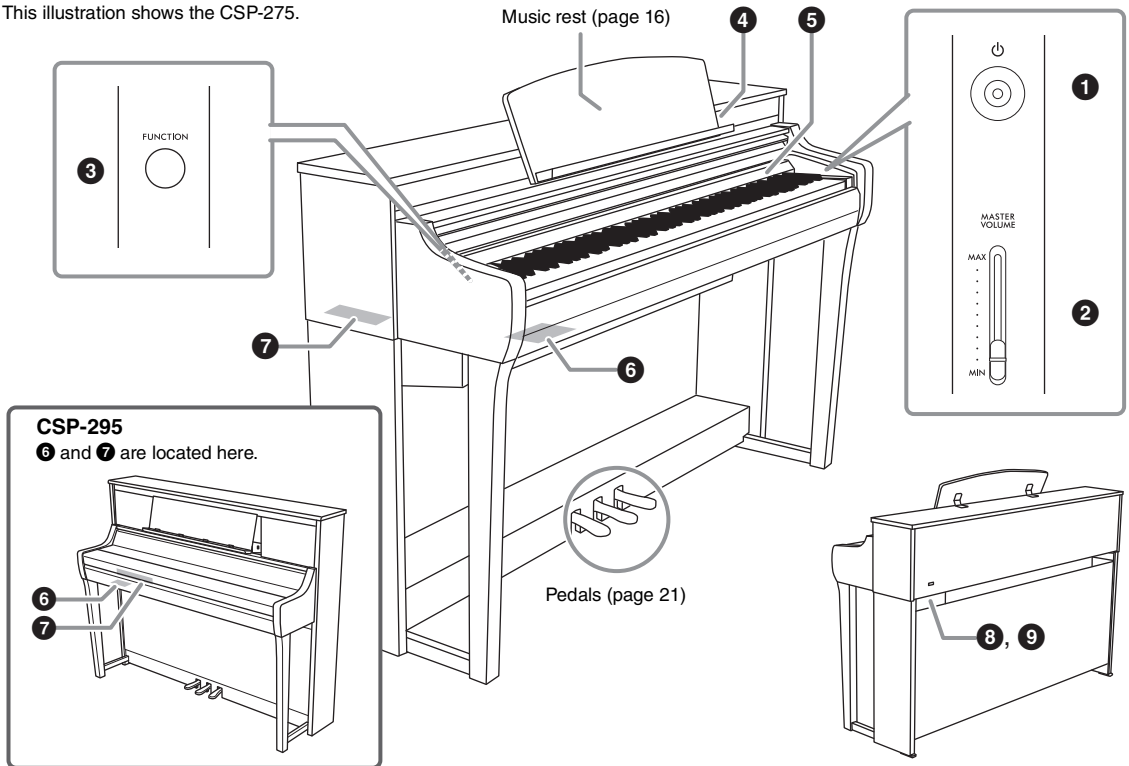

1 [⏻] (Standby/On) switch (page 19)
 For turning the power on or setting it to standby.

2 [MASTER VOLUME] slider (page 21)
 For adjusting the overall volume.

3 [FUNCTION] button (page 30)
 While holding this button, pressing a specified key allows you to call up the function assigned to the key.

4 [USB-C] terminal (pages 28, 39)
 For connecting to a smart device or a computer.



5 Stream Lights (page 32)
 There are four “Stream Lights” lamps embedded in the on top of each key, and these lamps light in succession in a descending pattern during Song playback to indicate the notes you should play and when you should play them.

6, 7 I/O connectors (page 14)
 For connecting external devices.

8 AC IN jack (page 19)
 For connecting the power cord.

9 [PEDAL] jack (page 49)
 (Not accessible on the CSP-295)
 For connecting the pedal cord.

[USB-C] terminal of the CSP-295GP
 The [USB-C] terminal is hidden under the cover at the rear of the music rest.

When using the terminal, first raise the music rest (page 16), and then open the cover. After connecting a plug to the [USB-C] terminal, the cover can be closed by passing the USB cable through the slit on the cover. To use the smart device, place it at the front of the music rest and connect the USB cable extending out under the music rest.

The diagram consists of two parts. The left part shows the 'Rear of the music rest' with a 'Cover' being lifted. The right part shows the 'Rear of the music rest' with the 'Cover' open, revealing the '[USB-C] terminal'.

6 I/O connectors (located at the bottom left of the keyboard)

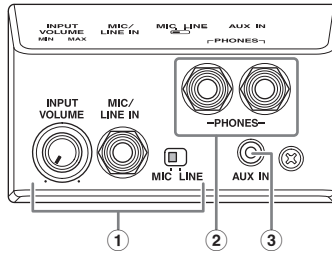

- ① **[INPUT VOLUME] knob, [MIC/LINE IN] jack, [MIC/LINE] switch (page 42)**
For connecting a microphone or guitar, etc. to output the sound from the speakers of this instrument.
- ② **[PHONES] jacks (page 22)**
For connecting a set of headphones.
- ③ **[AUX IN] jack (page 40)**
For inputting the sound of an audio player and listening to it through the built-in speakers of this instrument.

7 I/O connectors (see page 12 for the location on each instrument)

CSP-295GP/CSP-295

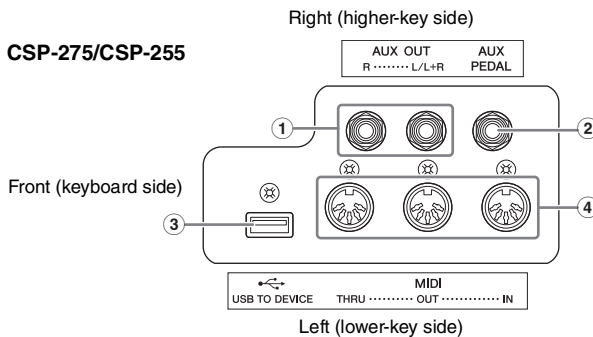

- ① **AUX OUT [R], [L/L+R] jacks (page 40)**
For connecting external audio devices, such as speakers. The sound of this instrument can be heard from the external speakers.
- ② **[AUX PEDAL] jack (page 41)**
For connecting a separately sold pedal.
- ③ **[USB TO DEVICE] terminal (page 27)**
For connecting a separately sold USB wireless LAN adaptor.
- ④ **MIDI [THRU], [OUT], [IN] terminals (page 43)**
For connecting to an external MIDI device.

Starting Up

This section explains how to set up and start using your instrument. Setup is so simple, you can start playing right away.

Opening/Closing the key cover

CAUTION

- Hold the key cover with both hands when opening or closing it. Do not release it until it is fully opened or closed. Be careful to avoid catching fingers (yours or others, especially children's) between the cover and the unit.
- Do not place anything (such as metal objects or pieces of paper) on top of the key cover. Small objects placed on the key cover may fall inside the unit when the cover is opened and may be nearly impossible to remove. Once inside, they could cause electric shock, short circuit, fire or other serious damage to the instrument.

NOTICE

Do not rest your weight on, or place heavy objects on the instrument, especially around the key cover and the music rest. Doing so can cause damage or malfunction of the key cover.

■ CSP-295

To open the key cover, lift the key cover with both hands and open it gently.

To close the key cover, pull the key cover with both hands, and lower it. The key cover is equipped with the special SOFT-CLOSE™ mechanism which closes the cover slowly.

CAUTION

Be careful to avoid catching your fingers when opening or closing the cover.

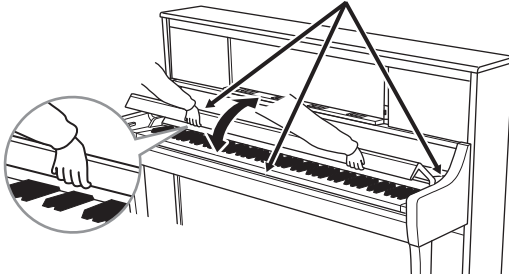

CAUTION

Do not apply excessive force when closing the key cover. Applying excessive force to the key cover when closing it could damage the SOFT-CLOSE™ mechanism, and possibly result in injury to your hands and fingers if they are caught under the closing key cover.

■ CSP-295GP/CSP-275/CSP-255

To open the key cover, lift the cover slightly with both hands, and then slide it to the end completely.

To close the key cover, slide the cover toward you with both hands, and then lower it gently.

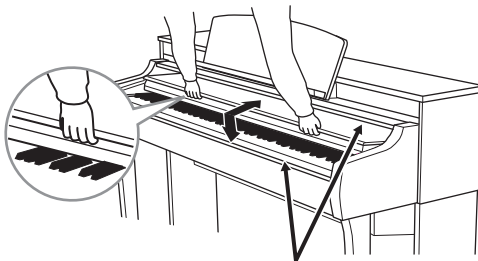

CAUTION

Be careful to avoid catching your fingers when opening or closing the cover.

Using the music rest

You can put a smart device or music books on the music rest. The music braces on the music rest prevent the smart device from falling down or allow you to hold the pages of music books in place.

NOTICE

If you use a smart device in an unstable position, the smart device could drop from its position and result in damage. When you put a smart device on the music rest, make sure that it is fully resting against the music rest and raise the music braces to hold it in place.

■ CSP-295GP

To raise the music rest:

- 1 Pull the music rest up and toward yourself as far as it will go.
- 2 Flip down the two metal supports at the left and right on the rear of the music rest.
- 3 Lower the music rest so that the metal supports latch into place.
- 4 If necessary, raise the music braces.

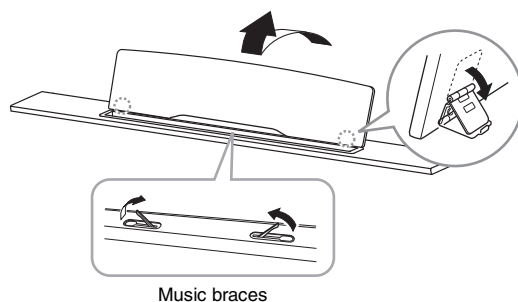

To lower the music rest:

- 1 Pull the music rest toward yourself as far as it will go.
- 2 Raise the two metal supports (at the rear of the music rest).
- 3 Gently lower the music rest backward until it is all the way down.
Lower the music braces when you are not using them.

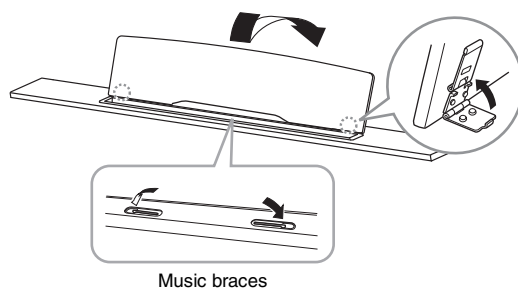

■ CSP-295

We recommend that you close the key cover to make it easier to hold the music rest.

To use the music rest, hold the bottom of the music rest, and then pull it towards yourself until it locks into place.

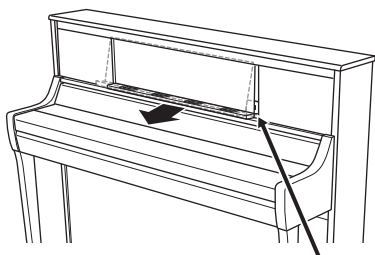

To put the music rest back, pull the music rest toward yourself as far as it will go, and then put it back gently.

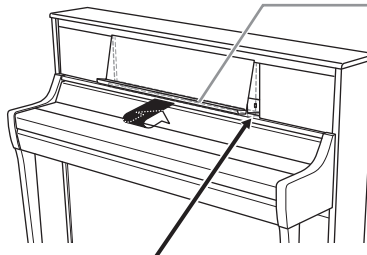

Music braces

Raise to use.

Close after using.



CAUTION

Be careful to avoid catching your fingers when moving the music rest.

To use the music braces, raise them toward yourself as far as they will go. When you are not using them, close them back.

■ CSP-275/CSP-255

Before using the music rest, make sure that the music rest is properly attached, and the screws are tightened securely (step 8 on page 50).

⚠ CAUTION

If excessive force is applied to the music rest, the music rest and screws could loosen or break, resulting in damage or even personal injury. If the music rest becomes detached, reattach it referring to page 50. If the screws become loose, tighten them up again.

To use the music braces, raise them toward yourself as far as they will go. When you are not using them, close them back.

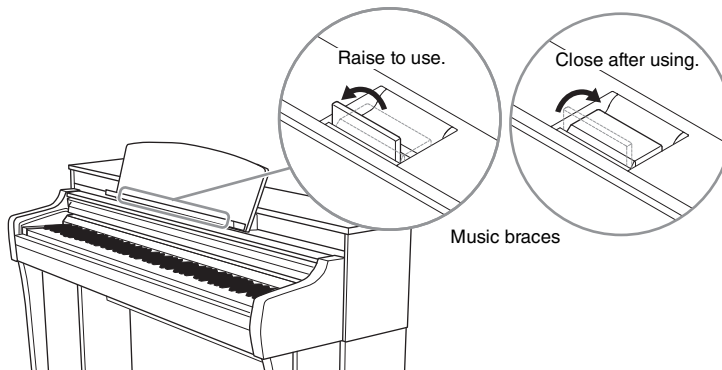

Opening/Closing the Lid (CSP-295GP)

⚠ WARNING

Do not let children open or close the lid. Also, be careful to avoid catching fingers (yours or others, and especially those of children) when raising or lowering the lid.

To open the lid:

- 1 Raise and hold the right side of the lid (viewed from the keyboard end of the instrument).
- 2 Raise the lid stay and carefully lower the lid so that the end of the stay fits into the recess in the lid.

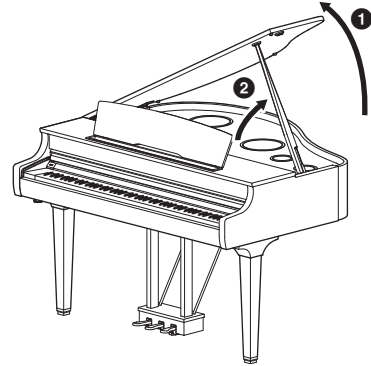

⚠ WARNING

- Make sure that the end of the stay fits securely in the lid recess. If the stay is not properly seated in the recess, the lid may fall, causing damage or injury.
- Be careful that you or others do not bump the stay while the lid is raised. The stay may be dislodged from the lid recess causing the lid to fall.

For the longer stay, use the inner recess, and for the shorter stay, use the outer recess to support the lid.

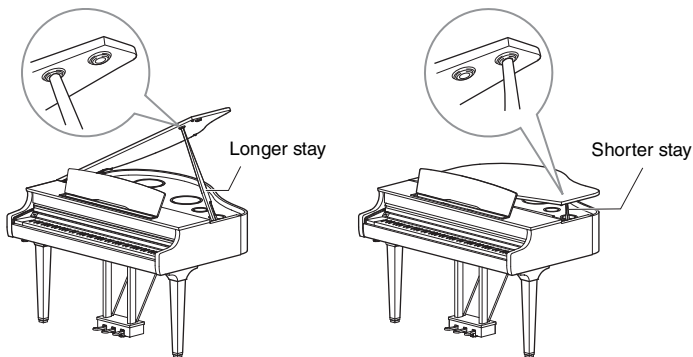

⚠ WARNING

Do not use the outer recess for the longer stay. Doing so makes the lid unstable and may cause it to fall, resulting in damage or injury.

To close the lid:

- 1 Hold the lid stay and carefully raise the lid.
- 2 Hold the lid in its raised position and lower the lid stay.
- 3 Carefully lower the lid.

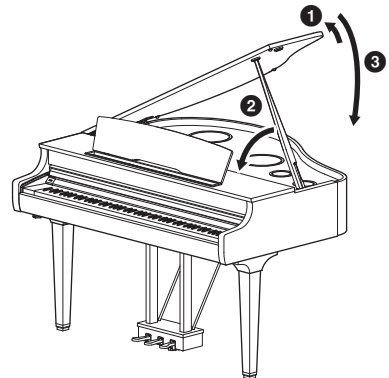

Power supply

Connect the plugs of the power cord in the order shown in the illustration. In some areas a plug adaptor may be provided to match the pin configuration of the AC wall outlets in your area.

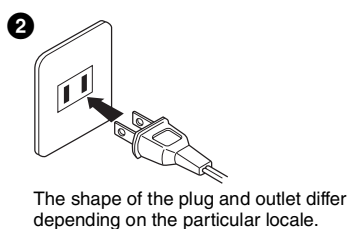
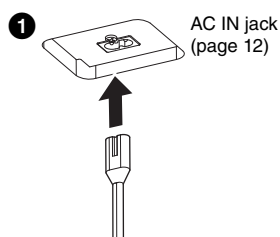

⚠ WARNING

Use only the supplied power cord. Do not use the power cord for other products.

⚠ CAUTION

When setting up the product, make sure that the AC outlet you are using is easily accessible. If some trouble or malfunction occurs, immediately turn off the power switch and disconnect the plug from the outlet.

NOTE

When disconnecting the power cord, first turn off the power, then follow this procedure in reverse order.

Turning the power on or off

1 Turn down the [MASTER VOLUME] slider to “MIN.”

2 Press the [⏻] (Standby/On) switch to turn the power on.

The power indicator on the [⏻] (Standby/On) switch lights up. After that, the Stream Lights (page 32) located above the highest key flash a few seconds, and the instrument starts up.

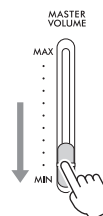

The power indicator lights up.

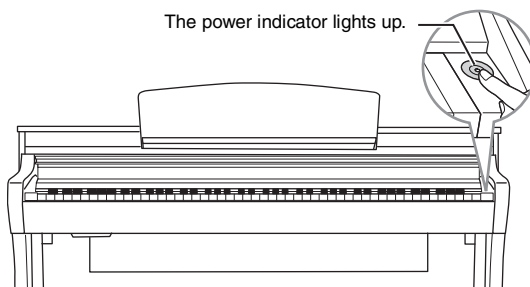

3 After you finish using the instrument, turn off the power by pressing the [⏻] (Standby/On) switch for a second.

The power indicator on the [⏻] (Standby/On) switch is turned off.

⚠ CAUTION

Even when the [⏻] (Standby/On) switch is in standby status, electricity is still flowing to the instrument at the minimum level. Remove the electric plug from the outlet when the instrument is not to be used for extended periods of time, or during electrical storms.

NOTICE

- Do not press any keys or pedals until the instrument has completely started up (the Stream Lights stop flashing) after turning on the power. Doing so may cause malfunction.
- If you need to force-quit the instrument, hold down the [⏻] (Standby/On) switch for longer than three seconds. Keep in mind that the force-quit operation might cause data loss and damage to the instrument.

Data retained even when the power is turned off (Backup data)

The following settings are retained even when the power is turned off.

- Tuning (page 36)
- Touch Sensitivity setting (page 35)
- Metronome volume (page 34)
- Elapsed time for Auto Power Off function (see below)
- Bluetooth on/off (page 26)
- Audio loopback on/off (page 37)
- Grand Expression Modeling type *
- Each Key Setting *

* These settings are available on [Piano Room] of Smart Pianist.

NOTE

If you want to keep other settings, use the Registration Memory on Smart Pianist.

What is Grand Expression Modeling?

On an actual acoustic piano, subtle changes in the sound can be produced by changing your playing touch from when you press a key to when you release it. For example, when you press a key all the way to its bottom, the key hits the keybed underneath and the noise reaches the strings, changing the sound slightly. Furthermore, the tone when the damper is lowered onto strings to mute the sound is changed by how quickly you release the key. The Grand Expression Modeling technology recreates these subtle changes in the sound that respond to your touch. This allows you to add accents by playing strongly or add resonance by playing softly to produce superbly expressive sound. A crisp tone can be heard when playing staccato as well as a lingering sound produced when releasing the keys slowly.

On this instrument, Grand Expression Modeling is effective only for the Voices of “CFX Grand” and “Bösendorfer.”

Auto Power Off function

To prevent unnecessary power consumption, this instrument features an Auto Power Off function that automatically turns the power off if the instrument is not operated for a specified period of time. The amount of time that elapses before the power is automatically turned off is approximately 30 minutes by default; however, you can change the setting from [Utility] → [System] on Smart Pianist.

NOTICE

Any data which are not saved will be lost if the power automatically turns off.

Disabling Auto Power Off (simple method)

Turn the power on while holding down the lowest key on the keyboard. The instrument starts up with the Auto Power Off function disabled.

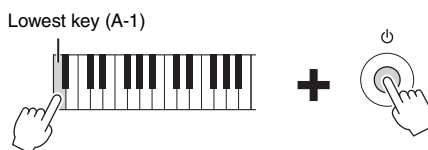

NOTE

You can enable/disable the Auto Power Off function by using the [FUNCTION] button (page 30).

Adjusting the Master Volume

To adjust the volume, use the [MASTER VOLUME] slider located at the right of the panel. Play the keyboard to check the sound while you adjust the volume.

CAUTION

Do not use the instrument at a high volume level for a long period of time, or your hearing may be damaged.

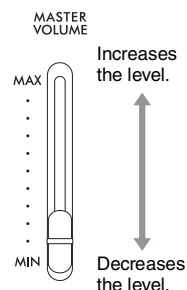

Intelligent Acoustic Control (IAC)

IAC is a function which automatically adjusts and controls the sound quality according to the overall volume of the instrument. Even when playing the instrument with the overall volume turned down, it permits both low sounds and high sounds to be clearly heard. IAC is effective only from the sound output of the instrument speakers. This function is set to on by default; however, you can turn it on or off, and set the depth from [Utility] → [Sound Setting] on Smart Pianist.

Using the pedals

This instrument is equipped with three foot pedals. Before using the instrument, rotate the adjuster under the pedal until it comes in firm contact with the floor surface so that the pedal box does not rattle or give way when you step on the pedals.

By default, the following functions are assigned to each pedal. You can also assign other functions such as “Style Start/Stop” to the pedals from [Utility] → [Pedal Setting] on Smart Pianist.

NOTICE

When moving the instrument, rotate the adjuster until it separates from the floor surface.

NOTE

The pedals are protected with vinyl covers when shipped from the factory. Remove the covers from the pedals before using to ensure optimum use of the pedal effects.

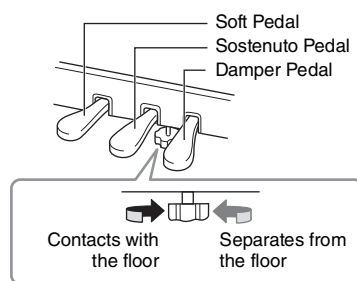

Damper pedal (right pedal)

When you press the damper pedal, the notes you play have a longer sustain. Pressing this pedal while you play a VRM Voice (page 23) recreates the characteristic string resonance of a real acoustic piano. You can use the Half-pedal function with this pedal.

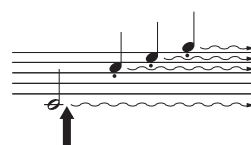

When you press the damper pedal here, the notes you play before you release the pedal have a longer sustain.

Half-pedal function

The Half-pedal function allows you to use half-damper techniques, in which the damper is pressed somewhere between all the way down and all the way up. In this half-damper state (on a real piano), the damper felts only partially mute the strings. This function lets you delicately and expressively control the damper muting, and create subtle nuances in your performance, by finely controlling the point at which pressure on the pedal affects the damper muting. The point is called “Half Pedal Point” and can be set in the [Piano Room] or [Utility] → [Pedal Setting] on Smart Pianist.

GP Response Damper (CSP-295GP/CSP-295 only)

The damper pedal of the CSP-295GP/CSP-295 has been designed to provide enhanced tactile response and, when pressed, is much closer in feel to the pedal of an actual grand piano. It makes it easier to physically experience the half-pedal point and more easily apply the half-pedal effect than other pedals.

Sostenuto pedal (center pedal)

If you play a note or chord on the keyboard and press the sostenuto pedal while holding the note(s), the notes will sustain as long as the pedal is held. All subsequent notes will not sustain.

NOTE

While the sostenuto (center) pedal is held, a sustained (non-decaying) type of Voice such as organ or strings may sound continuously without decay after the notes have been released.

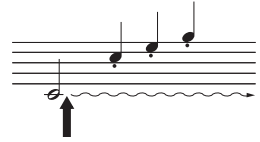

When you press the sostenuto pedal here while holding the note(s), the notes will sustain as long as you hold the pedal.

Soft pedal (left pedal)

The soft pedal reduces the volume and slightly changes the timbre of notes played while the pedal is pressed. The soft pedal will not affect notes that are already playing when it is pressed.

NOTE

When a Voice other than piano (such as Jazz Organ) is selected, a specific function appropriate for the Voice is automatically assigned to the left pedal.

Using headphones

Connect a pair of headphones to the [PHONES] jacks. Since this instrument is equipped with two [PHONES] jacks, you can connect two pairs of headphones. If you are using only one pair, insert the plug into either of these jacks.

CAUTION

Do not use the headphones for a long period of time at a high or uncomfortable volume level, since this can cause permanent hearing loss.

NOTE

When a plug is connected to the [PHONES] jack, no sound will come out from the instrument's speakers. If you are using an adaptor plug, be sure to remove this as well when unplugging the headphones.

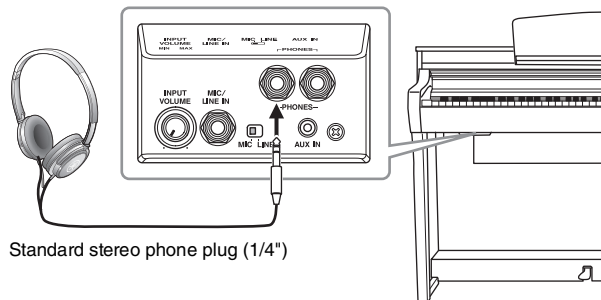

Standard stereo phone plug (1/4")

Using the headphone hanger

A headphone hanger is included in the instrument package so that you can hang the headphones on the instrument. Attach the headphone hanger by using the included two screws (4 × 10 mm) at the left front side as shown in the illustration.

NOTICE

Do not hang anything other than the headphones on the hanger. Otherwise, the instrument or the hanger may be damaged.

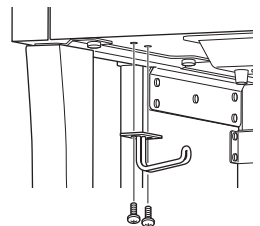

Reproducing the natural sensation of sound distance (even when using headphones)

This instrument features two advanced technologies that allow you to enjoy exceptionally realistic, natural sound, even when listening on headphones.

■ **Binaural Sampling**

Binaural Sampling is a method that uses two special microphones set at the ear position of a performer and records the sound from a piano as it would actually be heard. Listening to the sound with this effect through headphones gives the impression of being immersed in the sound, as if it was actually emanating from the piano. Moreover, you can enjoy the sound naturally for a long time without ear fatigue. When the “CFX Grand” or “Bösendorfer” (page 30) is selected, connecting the headphones automatically enables the binaural sampling sound.

Sampling

A technology which records the sounds of an acoustic instrument and then stores them to the tone generator to be played based on information received from the keyboard.

■ **Stereophonic Optimizer**

Stereophonic Optimizer is an effect which reproduces the natural sound distance, like with the sound of Binaural Sampling, even though you are listening to it on headphones. When one of the VRM Voices other than “CFX Grand” or “Bösendorfer” is selected, connecting the headphones automatically enables the Stereophonic Optimizer.

To see which Voices are VRM Voices, refer to the Data List on the website.

What is VRM?

On an actual acoustic piano, if you press the damper pedal and play a key, not only does the string of the pressed key vibrate, it also causes other strings and the soundboard to vibrate, each influencing the rest and creating a rich and brilliant resonance that sustains and spreads. The VRM (Virtual Resonance Modeling) technology featured in this instrument reproduces the complicated interaction of both string and soundboard resonance faithfully using a virtual musical instrument (physical modeling), and makes the sound more like a real acoustic piano. Since instantaneous resonance is made at the moment according to the state of the keyboard or pedal, you can vary the sound expressively by changing the timing of your pressing the keys, and the timing and depth of your pressing the pedal.

Playing with Smart Pianist

You can take greater advantage of this instrument and get even more enjoyment from it by connecting it to your smart device such as a smartphone or tablet, and using the Smart Pianist smart device app. Smart Pianist gives you convenient and powerful access to additional functions, such as recording and Registration Memory. Moreover, the display gives you exceptionally intuitive visual control, making it even easier to control the instrument.

NOTE

To see what you can do on the instrument by itself, or by using the Smart Pianist, refer to the list on page 54.

Installing Smart Pianist to your smart device



Get the Smart Pianist app and install it on your smart device!

- iPadOS/iOS: Available on the App Store
- Android: Available on Google Play

For details on the app and the compatible devices, see the website below.

<https://www.yamaha.com/kbdapps/>

Connecting with Smart Pianist

This instrument can be connected to a smart device wirelessly (page 27) or via a cable (page 28). For instructions on connecting the instrument with a smart device, the “Connection Wizard” of Smart Pianist will guide you according to the condition of the instrument you are using. If you want to connect via Bluetooth, read “Bluetooth connection” on page 25 beforehand, and then go on to the instructions below.

NOTICE

- All settings on the instrument are replaced by the settings on Smart Pianist when the instrument is connected with Smart Pianist.
- Do not place the smart device in an unstable position. Doing so may cause the device to fall and result in damage.



- 1 On Smart Pianist, tap the [≡] icon located at the upper left on the display to open the menu.
- 2 Tap [Instrument] to call up the Connection display.
- 3 Tap [Start Connection Wizard] at the bottom.
- 4 Follow the Connection Wizard.

When the connection is done successfully, the model name of the instrument such as “CSP-295” is shown next to [Instrument] located at the lower left on the display. After completing the connection, use Smart Pianist to control the instrument. While Smart Pianist is connected to the instrument, playing the keyboard is the only operation that can be done on the instrument.

Disconnecting Smart Pianist

If you close Smart Pianist on the smart device, the instrument is disconnected from the app. Pressing the [FUNCTION] button on the instrument can also disconnect the instrument from the app. Even if Smart Pianist is disconnected, you can use the instrument with the settings you've made on the app maintained until the power of the instrument is turned off.

■ To reconnect with Smart Pianist:

On the menu of Smart Pianist, tap [Instrument] to call up the Connection display (steps 1 – 2 on page 24), and then select the model name (such as CSP-295). If the model name is not shown in the Connection display, start the Connection Wizard again.

Connecting wirelessly

Connect the instrument with a smart device via Bluetooth (see below) or Wi-Fi (page 27).

Bluetooth connection

When connecting via Bluetooth, first make the Bluetooth Audio function settings on the instrument to enable receiving Audio data. After that, use Smart Pianist to connect via Bluetooth MIDI for transmitting/receiving MIDI data. Before using the Bluetooth function, be sure to read “About Bluetooth” on page 7.

Bluetooth capability

Depending on the country in which you purchased the product, the instrument may not have Bluetooth capability. If a “Y” indication is printed on the lower-right corner of the name plate at the bottom, the instrument does not have Bluetooth capability.

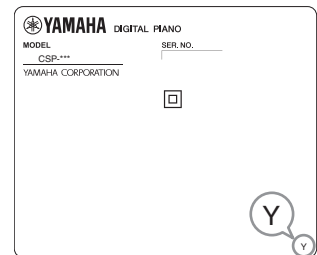

■ Bluetooth Audio connection (Bluetooth Audio function)

This section explains how to receive audio data from a Bluetooth-equipped device, such as a smartphone. When a Bluetooth-equipped device is connected, you can listen to the sound of audio data played on the connected device through the built-in speakers of the instrument.



NOTE

- In this manual, “Bluetooth-equipped device” refers to a device that can transmit audio data on it to the instrument using the Bluetooth function, via wireless communication. For proper operation, the device must be compatible with A2DP (Advanced Audio Distribution Profile). The Bluetooth Audio function is explained here by using a smart device as an example of such Bluetooth-equipped devices.
- This instrument cannot transmit audio data to the Bluetooth-equipped devices via Bluetooth. Thus, when the device is connected by Bluetooth, you cannot record in audio format by using Smart Pianist. If you want to record while Bluetooth connection, record in MIDI format. You can record in audio format when the instrument is connected to the smart device in a method other than Bluetooth.

- 1 While holding down the [FUNCTION] button, press the highest key (C7) to pair with a smart device.

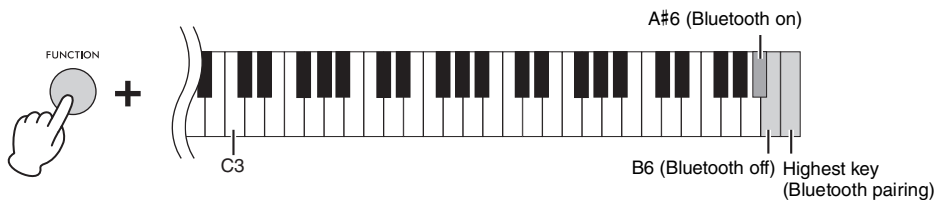

The Stream Lights (blue) of the right-most black key flash in succession downward while pairing. To cancel the pairing, press the [FUNCTION] button.

NOTE

- “Pairing” means to register Bluetooth-equipped devices on this instrument, and establish the mutual recognition for wireless communication between the two.
- The Bluetooth function of the instrument should be on to start pairing. It is set to on by default. To turn the Bluetooth function on/off, press the A#6 key or B6 key while holding down the [FUNCTION] button.
- Only one Bluetooth-equipped device can be connected to this instrument at a time (although up to 8 devices can be paired to this instrument). When pairing with the 9th device has succeeded, pairing data for the device with the oldest connection date will be deleted.

- 2 On the smart device, set the Bluetooth function to on and select “CSP-*** (model name) AUDIO” from the connection list.

After pairing is completed, the Stream Lights (blue) of the right-most black key flash for about three seconds.

If the Stream Lights do not flash, turn off the Bluetooth function by pressing the B6 key while holding down the [FUNCTION] button. After that, turn on the Bluetooth function by pressing the A#6 key while holding down the [FUNCTION] button, and then try the procedures from step 1 again.

NOTE

- Make sure to complete the settings on the smart device within 5 minutes.
- If you are prompted to enter a passkey, enter the numerals “0000.”

- 3 Play back audio data on the smart device to confirm that the built-in speakers of the instrument can output the audio sound.

When you turn on the instrument the next time, the last-connected smart device will be connected to this instrument automatically, if the Bluetooth function of the smart device and the instrument is set to on. If it is not connected automatically, select the model name of the instrument from the connection list on the smart device.

■ **Bluetooth MIDI connection**

To connect to a smart device via Bluetooth MIDI, follow the guide of the Connection Wizard on Smart Pianist (steps 1 – 4 on page 24). From the connection list, select “CSP-*** (model name) MIDI.”



NOTE

The Bluetooth function of the instrument should be on for the connection. It is set to on by default. To turn the Bluetooth function on/off, press the A#6 key or B6 key while holding down the [FUNCTION] button (step 1 on above).

Wi-Fi (Wireless LAN) connection

For Wi-Fi connection, you need a separately sold wireless LAN adaptor (UD-WL01). Before connecting the wireless LAN adaptor, be sure to read “Precautions when using the [USB TO DEVICE] terminal” below.

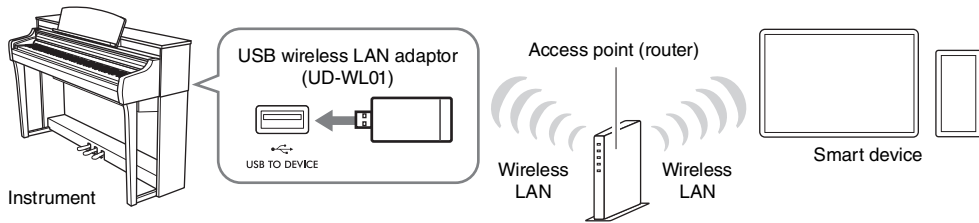

NOTICE

Do not connect this product to a public Wi-Fi and/or Internet service directly. Only connect this product to the Internet through a router with strong password protections. Consult your router manufacturer for information on optimum security practices.

NOTE

The instrument can be connected via Wi-Fi directly without need of an access point. However, in this condition Internet access will be disabled on your smart device, and certain functions may be limited, such as mailing, searching and some functions of Smart Pianist.

Stream Lights behavior when connecting by WPS

While setting up using an access point that supports WPS connection by Wi-Fi, the Stream Lights (blue) of the left-most black key flash in succession downward.

If the connection is completed, the four Stream Lights flash for about three seconds all together, and you can check the connection on Smart Pianist. If the connection fails, the Stream Lights do not flash.

WPS (Wi-Fi Protected Setup)

WPS refers to structure to easily make settings of a wireless LAN, just by pressing the WPS button. This helps you save time and effort in making the settings necessary for connecting to a network.

Precautions when using the [USB TO DEVICE] terminal

This instrument features a built-in [USB TO DEVICE] terminal. When connecting a USB device to the terminal, be sure to handle the USB device with care. Follow the important precautions below.

NOTE

For more information about the handling of USB devices, refer to the owner's manual of the USB device.

Compatible USB devices

- USB wireless LAN adaptor (UD-WL01; sold separately)
- USB flash drive (can only be used to update the software; not for use in saving files, reading data, recording nor playing back)

Other USB devices such as a USB hub, computer keyboard or mouse cannot be used.

NOTICE

The rating of the [USB TO DEVICE] terminal is a maximum of 5V/500mA. Do not connect USB devices having a rating above this, since this can cause damage to the instrument itself.

Connecting a USB device

When connecting a USB device to the [USB TO DEVICE] terminal, make sure that the connector on the device is appropriate and that it is connected in the proper direction.

NOTICE

- Avoid connecting or disconnecting the USB device when accessing the USB device. Failure to observe this may result in “freezing” of the operation of the instrument or corruption of the USB device and the data.
- When connecting and then disconnecting the USB device (and vice versa), make sure to wait a few seconds between the two operations.
- Do not use an extension cable when connecting a USB device.

Connecting via cables

Connect the smart device to the [USB-C] terminal by using a USB cable. Make sure that the USB cable has appropriate connectors (and an appropriate USB conversion adaptor, if necessary).

On the CSP-295GP, the [USB-C] terminal is located at the rear of the music rest; on the other models, it is located at the right end of the music rest. The device connected to this terminal is automatically charged during use.

NOTE

(CSP-295GP) For more information on the [USB-C] terminal, refer to page 13.

(CSP-295) When connecting or disconnecting a cable, we recommend that you pull the music rest toward yourself and hold it for easier access to the jack.

■ USB Type C connector devices

Connect a USB cable (Type C male - Type C male) in the order shown in the illustration.

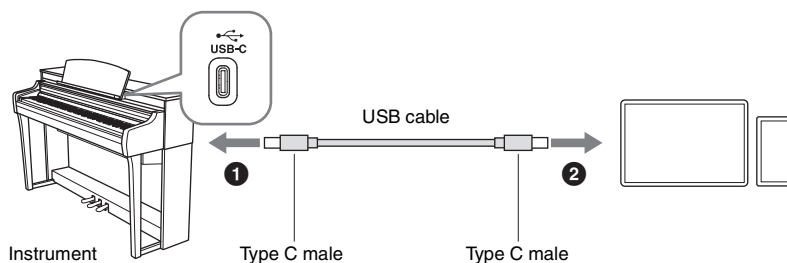

■ Lightning connector devices

Connect a USB cable (Type C male - Type C male) and a USB conversion adaptor (Type C female - Lightning) in the order shown in the illustration.

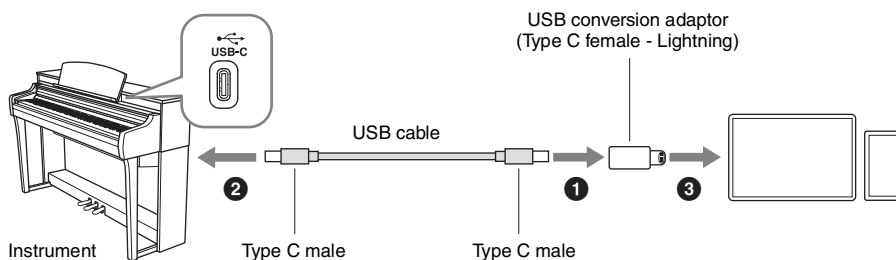

You can also simply use just an Apple USB-C to Lightning cable for the connection.

NOTICE

When using a USB-C to Lightning cable, use a genuine Apple cable.

NOTE

If you disconnect the cable from the smart device's connector and reconnect it, Smart Pianist may not be properly connected. If this happens, disconnect the cable from the [USB-C] terminal of the instrument and connect it again, or turn the power of the instrument off and turn it on again.

Precautions when using the [USB-C] terminal

When connecting a smart device or a computer to the [USB-C] terminal, make sure to observe the following points to avoid freezing the smart device, computer or instrument, and corrupting or losing the data.

NOTICE

- Use a CC type or AC type (page 39) USB cable of less than 3 meters. USB 3.0 cables cannot be used.
- Execute the following before turning the power to the instrument on/off or plugging/unplugging the USB cable to/from the [USB-C] terminal.
 - Quit any open app on the smart device.
 - Make sure that data is not being transmitted from the instrument. (Data is transmitted even when the notes on the keyboard are played or a Song is played back.)
- While the smart device is connected to the instrument, you should wait for six seconds or more between these operations: (1) when turning the power of the instrument off then on again, or (2) when alternately connecting/disconnecting the USB cable.

If the smart device, computer or instrument freezes, restart the app or the smart device/computer, or turn the power to the instrument off then on again.

Playing the Instrument Stand-alone

This chapter explains about the functions that can be controlled by using this instrument alone (without Smart Pianist). When the instrument is connected with Smart Pianist, you cannot control by using the instrument. Disconnect the instrument from Smart Pianist (page 25) to control by the instrument.

Function List

While holding down the [FUNCTION] button, pressing a specified key allows you to call up the function assigned to the key.

FUNCTION +

Key	Function
A#-1	Auto Power Off enable
C0	CFX Grand
D0	Concert Upright
D#0	Suitcase Jazz
E0	Vintage EP
F0	DX Dynamic
G0	Pipe Organ Principal
G#0	Jazz Rotary SW
A0	Harpsichord 1
B0	Vibraphone
C1	Into The Unknown
D1	Señorita
E1	My Heart Will Go On
F1	Canon D dur
G1	Twinkle, Twinkle, Little Star
A1	Für Elise
B1	Jesus, Joy of Man's Desiring
C2	Standard 8Beat
D2	Funky Shuffle
E2	6-8 Ballad Rock
F2	Mod Broadway Ballad
G2	Swing Medium
A2	Brazilian Bossa
B2	Cool Jazz Waltz
B2	Easy Waltz

Auto Power Off (page 20) **Voices (page 32)** **Songs (page 32)** **Styles (page 33)**

Voice List

Key	Voice name	Description
C0	CFX Grand*	Yamaha's CFX flagship concert grand piano sound with a wide dynamic range for maximum expressive control. Suitable for playing in any music genre and style.
C#0	Bösendorfer*	The famed sound of the Vienna-made Bösendorfer Imperial concert grand piano. Its spacious sound evokes the size of the instrument, and is ideal for expressing tenderness in compositions.
D0	Concert Upright	The sound sampled from an upright piano, the Yamaha SU7. Enjoy the unique tonal character and a lighter, more casual feel.
D#0	Suitcase Jazz	The sound of an electric piano using hammer-struck metallic "tines," featuring a soft tone when played lightly, and an aggressive tone when played hard. The characteristic sound fits various popular music genres, such as jazz.
E0	Vintage EP	The sound of an electric piano using hammer-struck metal reeds. Widely used in rock and popular music.
F0	DX Dynamic	An electronic piano sound produced by an FM synthesizer. The tone will change as you vary your playing touch. Ideal for popular music.
F#0	Jazz Rotary SW	The sound of a "tonewheel" type electric organ. Sampled with Rotary speaker effect, its rotation speed is changed when you press the left pedal. Often heard in jazz and rock idioms.
G0	Pipe Organ Principal	This Voice features the combination of pipes (8'+4'+2') of a principal (brass instrument) organ. It is suitable for Baroque church music.
G#0	Harpsichord 1	The sound of the instrument frequently used in baroque music. Variations in playing touch will not affect the volume, and a characteristic sound will be heard when you release the key.
A0	Vibraphone	A Vibraphone sound with vibrato effect. Its spacious and clear sound is ideal for popular music.

When the Voice marked by "*" is selected, connecting the headphones automatically enables Binaural Sampling sound (page 23).

Voice: Instrument sound for playing from the keyboard.
Song: Data of songs.
Style: Automatic accompaniment and rhythmic backing pattern.

NOTE

During Bluetooth pairing or playing back the Song/Style/metronome, pressing only the [FUNCTION] button allows you to stop the function that is being used. In other cases, pressing the [FUNCTION] button calls up the "CFX Grand" Voice.

C#3 D#3			F#3 G#3 A#3			C#4 D#4			F#4 G#4 A#4			C#5 D#5			F#5 G#5 A#5			C#6 D#6			F#6 G#6 A#6												
Metronome on/off	Number key 1	Number key 2	Number key 3	Number key 4	Number key 5	Number key 6	Number key 7	Number key 8	Number key 9	Number key 0	Tap Tempo	Beat down 1	Beat up 1	Volume down 1	Volume up 1	All	Rhythm	Recital Hall	Chamber	Club	No Effect	Touch Sensitivity	Semitone down	Semitone up	Lower approx. 0.2 Hz	A3 = 440.0 Hz	Raise approx. 0.2 Hz	A3 = 442.0 Hz	Channel down 1	Channel up 1	Loopback Off	Bluetooth Off	Bluetooth pairing
C3	D3	E3	F3	G3	A3	B3	C4	D4	E4	F4	G4	A4	B4	C5	D5	E5	F5	G5	A5	B5	C6	D6	E6	F6	G6	A6	B6	C7					
Metronome						Number keys			Beat			Style Part (page 33)			Reverb Type (page 35)			Transpose (page 36)			Tuning (page 36)			MIDI Channel (page 37)			Bluetooth connection (page 26)						
Metronome / Tempo (page 34)						Tap Tempo			Metronome Volume						Touch Sensitivity (page 35)						Audio Loopback (page 37)												

Song List

Key	Song name	Composer
C1	Into The Unknown	See pages 56 – 57.
C#1	10,000 Hours	
D1	Señorita	
D#1	Clocks	
E1	My Heart Will Go On (Love Theme From "Titanic")	
F1	Canon D dur	J. Pachelbel
F#1	Jesus, Joy of Man's Desiring	J. S. Bach
G1	Twinkle, Twinkle, Little Star	Traditional
G#1	Salut d'amour op.12	E. Elgar
A1	Für Elise	L. v. Beethoven

Style List

Key	Style name
C2	Standard 8Beat
C#2	Smooth Ballad
D2	Funky Shuffle
D#2	60s Big Hit
E2	6-8 Ballad Rock

Key	Style name
F2	Mod Broadway Ballad
F#2	Brazilian Bossa
G2	Swing Medium
G#2	Cool Jazz Waltz
A2	Easy Waltz

Playing with various sounds (Voices)

You can play the keyboard by using various instrumental Voices. While holding down the [FUNCTION] button, press one of the C0 – A0 keys to select the desired Voice (page 30). To reset to the default Voice (CFX Grand), press the [FUNCTION] button.

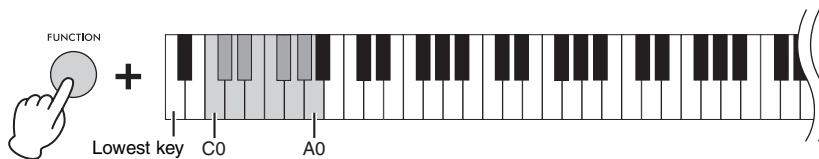

NOTE

If you use Smart Pianist, the Voices can be played via three keyboard parts: Main, Layer and Left. These playing modes allow you to play just one single Voice (Main part) over the entire keyboard, layer a different Voice (Layer part) to the Main part, or play a different Voice in the left-hand areas of the keyboard by turning the Left part on. When the Left part is turned on, the Stream Lights lights up at the point (called Split Point) which divides the keyboard into the left-hand and right-hand areas.

Playing back a Song

This section explains how to play the preset Songs (page 31).

- 1 While holding down the [FUNCTION] button, press one of the C1 – A1 keys.

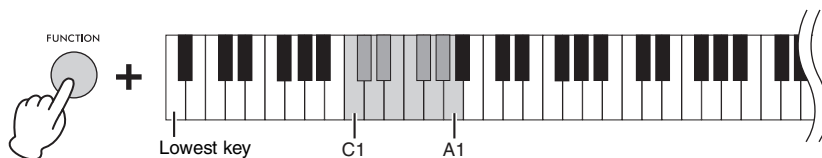

During Song playback, the Stream Lights indicate the notes you should play and when you play them. As the lights “descend,” play the indicated key when the light reaches the bottom, nearest the key.

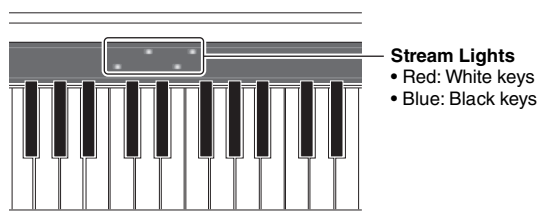

The Stream Lights speed and the on/off status can be set from [Song] → (Song select) → [Setting] → [Playback] on Smart Pianist.

NOTE

To change the tempo, refer to page 34.

- 2 Press the [FUNCTION] button to stop playback.

The ten preset Songs are played back continuously until you stop playback.

NOTE

You can use the Guide function on Smart Pianist. When it is turned on, you can practice at your own pace — since the playback of other parts will wait for you to play the notes correctly.

Playing with a Style

This instrument features “Styles” that produce automatic accompaniment playback in response to your playing of the keyboard.

- 1 While holding down the [FUNCTION] button, press one of the C2 – A2 keys.**
The rhythm part of the selected Style (page 31) starts playback.

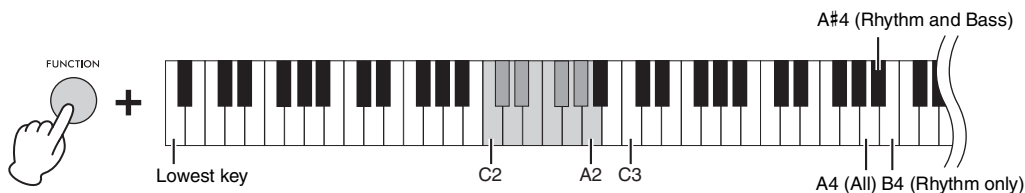

NOTE

To adjust the tempo, refer to page 34.

- 2 Play the keyboard along with the rhythm part.**

As soon as you play a key, the bass part and other parts start playing. Just by playing the keyboard, the instrument detects the chords and automatically plays the accompaniment along with your performance.

A Style consists of rhythm, bass and other parts. All these parts are played back by default, but you can specify the parts to be played. While holding down the [FUNCTION] button, press one of the A4 – B4 keys.

NOTE

If you set the Chord Detection Area to “Lower” by using Smart Pianist, a specifically assigned left-hand section of the keyboard is used to specify chords, and chords played in this section are detected and used as a basis for automatic accompaniment with the selected Style. To restore the default setting, select “Full” as the Chord Detection Area.

- 3 After you have finished the performance, press the [FUNCTION] button to stop playback.**

An ending plays back before the Style stops.

Using the Metronome

By using the metronome, you can practice with an accurate tempo, and confirm the actual tempo by hearing it. While holding down the [FUNCTION] button, press the C3 key to turn on/off the metronome. You can also stop the metronome while it is playing back by simply pressing the [FUNCTION] button.

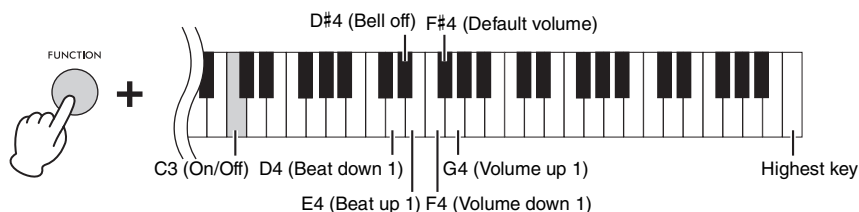

■ To adjust the volume

The volume can be adjusted over a range of 0 – 127. While holding down the [FUNCTION] button, press the F4 or G4 key. To reset to the default volume (100), simultaneously hold down the [FUNCTION] button and press the F#4 key.

■ To change the beat

The beat can be selected from 0, 2, 3, 4, 5 and 6. The first beat is accented with a bell sound and the rest with clicks. By default, it is set to 0 (Bell off) and clicks sound in all beats. While holding down the [FUNCTION] button, press the E4 or D4 key to change the beat up or down. To reset to the default, simultaneously hold down the [FUNCTION] button and press the D#4 key.

NOTE

To adjust the tempo, see below.

Adjusting the tempo

You can adjust the tempo of the Songs, Styles or metronome over a range of 5 – 500 beats per minute.

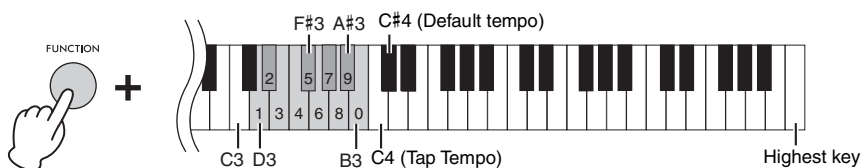

■ By inputting a three-digit value

While holding down the [FUNCTION] button, press the appropriate D3 – B3 keys one by one in order. For example, to specify “95,” while holding down the [FUNCTION] button, press the B3 (0), A#3 (9) and F#3 (5) keys in order.

■ By tapping at the desired tempo (Tap Tempo)

While holding down the [FUNCTION] button, tap the C4 key (twice or more) at the desired tempo to change the tempo.

To reset to the default tempo, simultaneously hold down the [FUNCTION] button and press the C#4 key. The default tempo differs depending on the selected Song or Style.

Selecting the Reverb type

An actual piano sounds differently depending on the room in which it is played. You can select the Reverb type which simulate the reverberation in the different rooms.

While holding down the [FUNCTION] button, press one of the C5 – F5 keys to select the Reverb type. The selected Reverb is applied to all the entire sound including the keyboard performance, Song/Style playback and MIDI playback input from an external MIDI device.

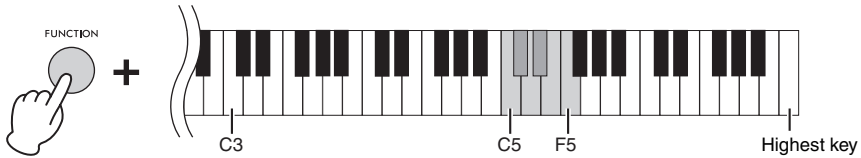

Reverb Type List

Key	Reverb type	Description
C5	Recital Hall	Simulates clear reverberation in a mid-sized hall suitable for piano recital.
C#5	Concert Hall	Simulates brilliant reverberation in a large hall for public orchestra performances.
D5	Chamber	Simulates the elegant reverberation in a small room suitable for chamber music.
D#5	Cathedral	Simulates the solemn reverberation in a high-ceiling stone-made cathedral.
E5	Club	Simulates the lively reverberation in a jazz club or a small bar.
F5	No Effect	No effect is applied.

NOTE

When a Style or Song is selected, the ideal Reverb type is automatically called up. For this reason, a type may be called up that is not available from the types above.

Setting the Touch Sensitivity of the keyboard

Touch Sensitivity determines how the sound responds to your playing strength. This setting does not change the weight of the keyboard. Simultaneously hold down the [FUNCTION] button and press the G5 key to toggle among the various settings: Medium, Hard 1, Hard 2, Fixed, Soft 2, Soft 1 and Medium. To reset to the default setting (Medium), simultaneously hold down the [FUNCTION] button and press the F#5 key.

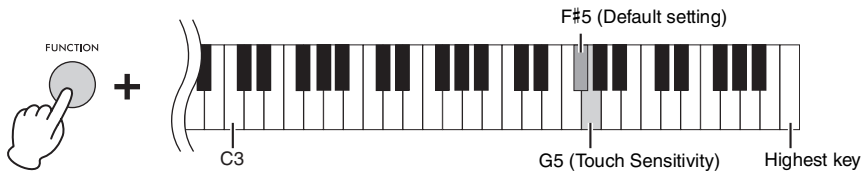

Touch Sensitivity List

Touch Sensitivity	Description
Soft 2	Produces relatively high volume even with light playing strength.
Soft 1	Produces high volume with moderate playing strength.
Medium	Standard Touch Sensitivity.
Hard 1	Requires moderately strong playing for high volume.
Hard 2	Requires strong playing to produce high volume.
Fixed	The volume level will be the same regardless of how hard you play the keys.

Transposing the pitch in semitones

You can shift the pitch of the entire keyboard up or down in semitones in order to facilitate playing in difficult key signatures, or to easily match the pitch of the keyboard to the range of a singer or other instruments.

While holding down the [FUNCTION] button, press the A5 or B5 key to shift the pitch up or down over a range of -12 – +12. To restore the default setting (normal pitch = 0), simultaneously hold down the [FUNCTION] button and press the A#5 key.

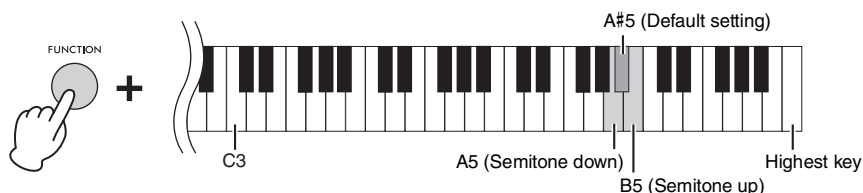

Fine-tuning the pitch

You can fine-tune the pitch of the entire instrument in approximately 0.2 Hz steps. This lets you accurately match the keyboard pitch to that of other instruments or recorded music.

While holding down the [FUNCTION] button, press the C6 or D6 key to raise or lower the pitch over a range of 414.8 – 466.8 Hz (=A3).

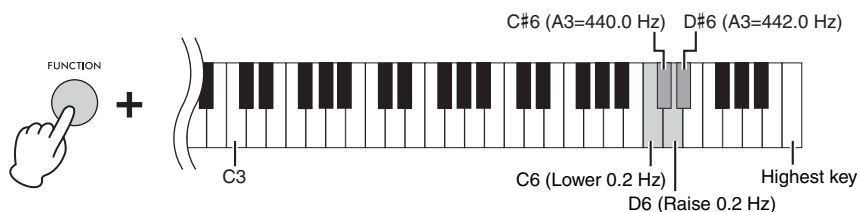

To set the pitch to 442.0 Hz (a pitch commonly used by brass and wind instruments), simultaneously hold down the [FUNCTION] button and press the D#6 key. To restore the default pitch (440.0 Hz), simultaneously hold down the [FUNCTION] button and press the C#6 key.

Changing the MIDI transmit channel

You can change the MIDI channel for transmitting MIDI messages of your keyboard performance from the MIDI [OUT] terminal to a connected MIDI device. The three keyboard parts are changed in conjunction. The default settings are as follows:

- Main part: MIDI port 1, channel 1
- Layer part: MIDI port 1, channel 2
- Left part: MIDI port 1, channel 3

While holding down the [FUNCTION] button, press the F6 or G6 key to change the channels up or down by one. To restore the default settings, simultaneously hold down the [FUNCTION] button and press the F#6 key.

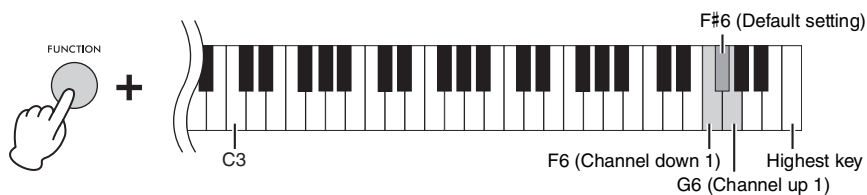

Example

Main part:	MIDI port 1, channel 6	Channel up 1 	channel 7
Layer part:	MIDI port 1, channel 7		channel 8
Left part:	MIDI port 1, channel 8		channel 1

NOTE

The channel of the Main part is the basis and can be changed over a range of 1 to 8. When the Main part's channel is 8, pressing "Channel up 1" (press the G6 key while holding down the [FUNCTION] button) does not change the channels of all three parts. When the Left part's channel is 8 (Main part is 6), pressing "Channel up 1" restores the Left part's channel to 1.

Turning Audio Loopback on/off

The Audio Loopback function allows you to set whether audio input sound from the smart device or computer is output to a smart device or a computer or not along with the performance played on the instrument. To output the audio input sound, set the Audio Loopback to on. For example, if you want to record the audio input sound as well as the sound played on the instrument by using the connected computer or smart device, set this to on. If you intend to record only the sound played on the instrument by using the computer or smart device, set this to off.

To turn this function on/off, simultaneously hold down the [FUNCTION] button and press the G#6 or A6 key.

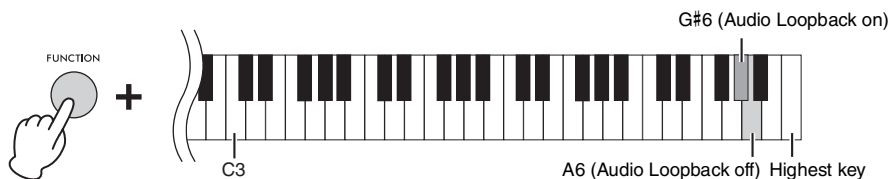

NOTE

- The audio input sound via the Bluetooth Audio function (page 25), USB Audio Interface function (page 40) or the Wi-Fi connection with Smart Pianist (page 27) can be output. The sound is output to the smart device or the computer connected via the USB Audio Interface function or Smart Pianist connected via Wi-Fi. The sound cannot be output to a Bluetooth device.
- When Audio Recording by using Smart Pianist, the audio input sound from the connected smart device or computer is recorded when this is set to on, and not recorded when set to off.

Resetting to the Factory-programmed Settings (Initializing)

Turn off the power once, and then simultaneously hold down the C7 (the highest) key and press the [⏻] (Standby/On) switch to turn on the power. This resets (or initializes) all of the settings (page 20) to their factory default, with the exceptions of Each Key Setting (page 20) and Bluetooth pairing information (page 26).

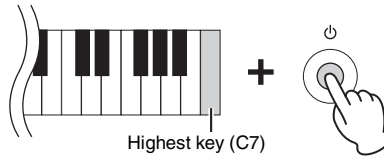

Connections

External devices can be connected to the jacks and terminals on this instrument. For information on the location of these connectors, refer to “Panel Controls and Terminals” on page 12. You can also connect a Bluetooth-equipped device, such as an audio player, by using the Bluetooth function*.

*For information on whether Bluetooth functionality is included or not, refer to page 25.

CAUTION

Before connecting the instrument to other electronic components, turn off the power of all the components. Also, before turning any components on or off, make sure to set all volume levels to minimum (0). Otherwise, damage to the components, electrical shock, or even permanent hearing loss may occur.

NOTICE

Do not place any external devices in an unstable position. Doing so may cause the device to fall and result in damage.

Listening to Audio data from a Bluetooth-equipped device through this instrument (Bluetooth Audio Function)

This instrument is equipped with the Bluetooth Audio function. You can play the sound of audio data saved in a Bluetooth-equipped device, such as a smartphone or portable audio player, on this instrument and listen to it through the built-in speaker of the instrument. For details, refer to page 25.

Connecting to a computer — [USB-C] terminal

By connecting a computer to the [USB-C] terminal, audio data or MIDI data can be transmitted/received between the instrument and the computer.

To connect via the [USB-C] terminal, use a USB cable with the proper connectors as shown below. Before using the [USB-C] terminal, be sure to read “Precautions when using the [USB-C] terminal” on page 29.

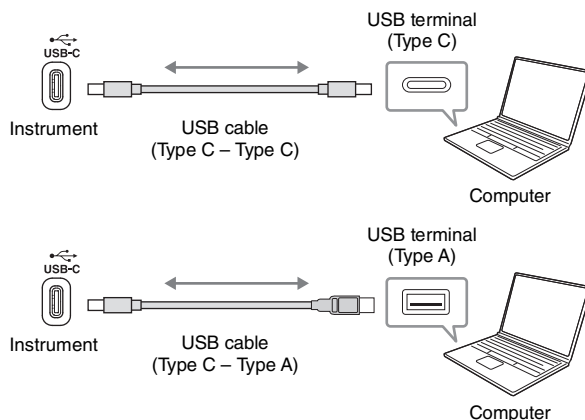

NOTE

- When using a USB cable to connect the instrument to your computer, make the connection directly without passing through a USB hub.
- The instrument will begin transmission a short time after the USB connection is made.
- Unexpected sounds may occur if you edit MIDI data related to the Grand Expression Modeling effect (page 20) on a computer.

Transmitting/Receiving Audio Data (USB Audio Interface function)

By connecting a computer or a smart device to the [USB-C] terminal via a USB cable, digital audio data can be transmitted/received. This USB Audio Interface function provides the following advantages:

■ Playing back audio data with high sound quality

This gives you direct, clear sound in which the sound quality has less noise and deterioration than that from the [AUX IN] jack.

■ Recording your performance on the instrument as audio data by using recording software or music production software

The recorded audio data can be played back on the computer or smart device.

⚠ CAUTION

If you are using a DAW (digital audio workstation) application with this instrument, set the Audio Loopback function (page 37) to off. Otherwise, a loud sound may occur, depending on the settings of the computer or the application software.

NOTE

- When transmitting or receiving audio signals by using a computer running Windows, the Yamaha Steinberg USB Driver should be installed to the computer. Download the driver from Yamaha Downloads (page 8) and install it to the computer.
- For instructions on connecting a smart device, see "Connecting via cables" on page 28 first, and then go on to the steps on page 24.

Turning Audio Loopback On/Off

You can set whether audio input sound from the computer or smart device is output to a computer or a smart device or not along with the performance played on the instrument. For details, refer to page 37.

Connecting to an external audio device — [AUX IN] jack, AUX OUT [R]/[L/L+R] jacks

Listening to playback on an audio player through the instrument's speaker

You can connect the headphone jack of an audio player, such as a smartphone or portable audio player to the instrument's [AUX IN] jack, and listen to the sound of that audio player through the built-in speakers of the instrument.

NOTICE

To avoid damage to the devices, first turn on the power to the external device, and then to the instrument. When turning off the power, do in reverse: first turn off the power to the instrument, and then to the external device.

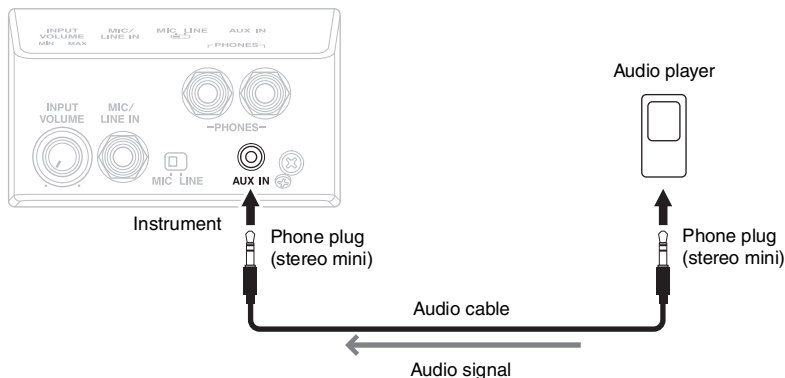

NOTE

- Use audio cables and adaptor plugs having no (zero) resistance.
- The USB Audio Interface function (see above) gives you direct, clear sound in which the sound quality has less noise and deterioration than that from the [AUX IN] jack.

Using an external stereo system for listening to sounds from the instrument

You can connect a stereo system to amplify the instrument's sound by using the AUX OUT [R]/[L/L+R] jacks. The sound input from the [AUX IN] jack and the [MIC/LINE IN] jack is output at the same time.

NOTICE

- To avoid possible damage, first turn on the power to the instrument, and then to the external device. When turning off the power, do in reverse: first turn off the power to the external device, and then to the instrument.
- Since this instrument's power may automatically be turned off due to the Auto Power Off function (page 20), turn off the power to the external device, or disable Auto Power Off when you do not intend to operate the instrument.
- Do not route the output from the AUX OUT jacks to the [AUX IN] jack. If you make this connection, the signal input at the [AUX IN] jack is output from the AUX OUT jacks. These connections could result in a feedback loop that will make normal performance impossible, and may even damage the equipment.

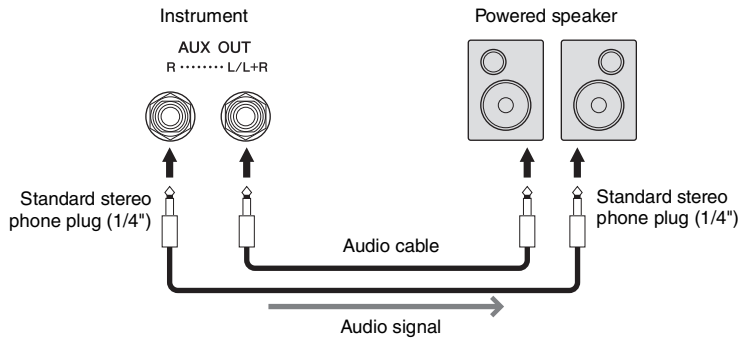

NOTE

- When connecting a mono device, use only the [L/L+R] jack.
- Use an appropriate adaptor plug if the input jack of the powered speaker does not match the phone plug of the audio cable.
- Use audio cables and adaptor plugs having no (zero) resistance.
- When you are monitoring the sound output via the AUX OUT jacks from headphones connected to the instrument, we recommend that you set the Binaural Sampling and Stereophonic Optimizer functions (page 23) to off. These can be turned on or off from [Utility] → [Sound Setting] → [Binaural] on Smart Pianist.

Connecting a footswitch/foot controller — [AUX PEDAL] jack

The FC4A/FC5 footswitch or the FC7 foot controller (sold separately) can be connected to [AUX PEDAL] jack. A footswitch can be used for switching functions on and off, while a foot controller controls continuous parameters such as volume. The function of the connected pedal can be set from [Utility] → [Pedal Setting] on Smart Pianist.

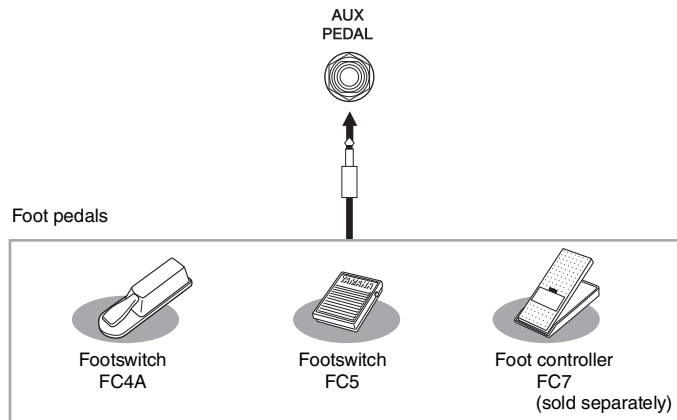

NOTE

- Make sure to connect or disconnect the pedal only when the power is off.
- Do not press the pedal while turning the power on. Doing this changes the recognized polarity of the pedal, resulting in reversed operation.

Connecting a microphone or guitar — [MIC/LINE IN] jack

The [MIC/LINE IN] jack (standard 1/4" phone jack) lets you connect a microphone, guitar, or other audio equipment.

- 1 **Before turning on the power of the instrument, set the [INPUT VOLUME] knob to the minimum position.**
- 2 **Connect the microphone or the guitar to the [MIC/LINE IN] jack.**

NOTE

Make sure you have a conventional dynamic microphone.

- 3 **Set the [MIC/LINE] switch to “MIC” or “LINE,” depending on the instrument to be connected.**

- **MIC:** For connecting an equipment with low output level (such as a microphone, guitar, bass)
- **LINE:** For connecting an equipment with high output level (such as a synthesizer, keyboard, CD player)

- 4 **Turn on the power of the instrument.**

- 5 **Adjust the [INPUT VOLUME] knob while singing into the microphone or playing the guitar.**

The microphone related settings such as Harmony and Reverb can be made from [Utility] → [Mic Setting] on Smart Pianist.

Disconnecting the microphone/guitar

Set the [INPUT VOLUME] knob to the minimum position, and then disconnect the microphone/guitar from the [MIC/LINE IN] jack.

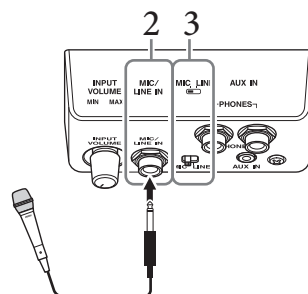
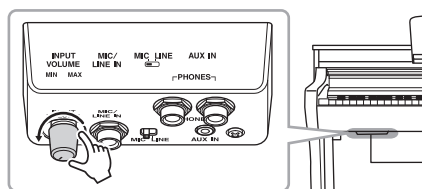

Connecting external MIDI devices — MIDI terminals

Use the MIDI terminals and standard MIDI cables to connect external MIDI devices (keyboard, sequencer, etc.).

MIDI [IN]: Receives MIDI messages from another MIDI device.

MIDI [OUT]: Transmits MIDI messages generated by the instrument to another MIDI device.

MIDI [THRU]: Simply relays the MIDI messages received at the MIDI [IN] terminal.

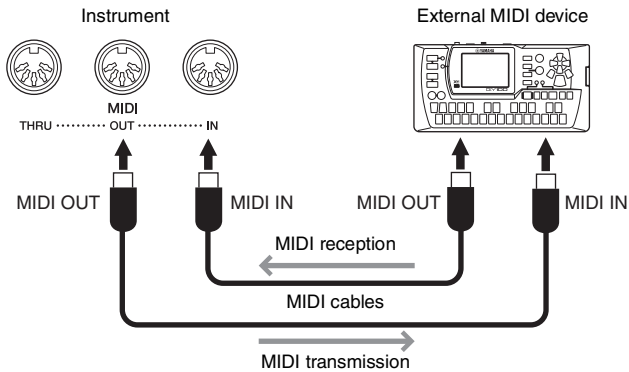

NOTE

- For details about MIDI, refer to "MIDI Basics" downloadable from Yamaha Downloads (page 8).
- When the instrument is connected to Smart Pianist, MIDI messages cannot be output from the MIDI OUT terminal.
- When transmitting MIDI data from this instrument to an external MIDI device, unexpected sounds may occur because of data related to the Grand Expression Modeling effect (page 20).

CSP-295GP Assembly

⚠ CAUTION

- Assembly should be carried out by at least four persons
- Assemble the unit on a hard and flat floor with ample space.
- Be careful not to confuse parts, and be sure to install all parts in the correct orientation. Please assemble the unit in accordance with the sequence given below.
- Be sure to use only the included screws of the specified sizes. Do not use any other screws. Use of incorrect screws can cause damage or malfunction of the product.
- Be sure to tighten all screws upon completing assembly of the unit.
- To disassemble the unit, reverse the assembly sequence given below.

Have a Phillips-head (+) screwdriver of the appropriate size ready.

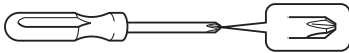

Remove all parts from the package and make sure you have all of the items.

Main unit

To prevent damage to the connector panels and the speakers located at the bottom of main unit, make sure to place main unit on the Styrofoam pads. Also, make sure that the pads do not touch the connector panels and the speakers.

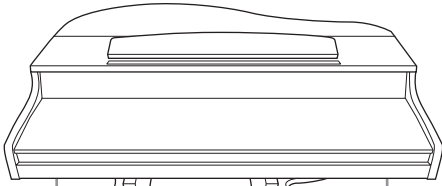

Connector panel Pads Connector panel

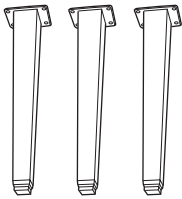

Legs

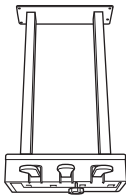

Pedal box

Bundled pedal cord inside.

NOTE

The pedals are protected with vinyl covers when shipped from the factory. Remove the covers from the pedals before using for optimum use of the pedal effect.

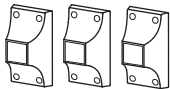

Leg beams

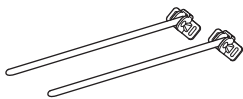

Lyre braces



Cord holder



6 x 40 mm fixing screws (12 pcs.)



6 x 20 mm fixing screws (4 pcs.)



Power cord

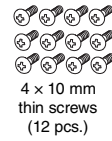

4 x 10 mm thin screws (12 pcs.)



4 x 16 mm thin screws (4 pcs.)



Headphone hanger

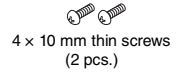

4 x 10 mm thin screws (2 pcs.)

1. Lean the main unit against the wall as shown below.

⚠ CAUTION

Be careful not to pinch your fingers.

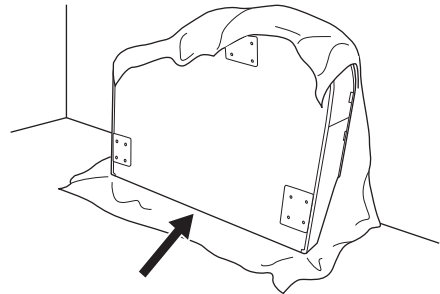

1-1. Spread a large soft cloth, such as a blanket, as shown to protect the floor and wall surfaces.

1-2. Lean the main unit against the wall with the key cover closed and the keyboard side on the bottom.

NOTICE

Do not place the main unit as shown in the illustration here.

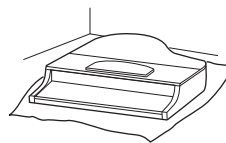

Incorrect

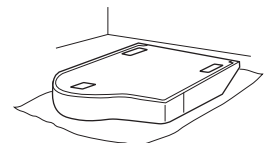

Incorrect

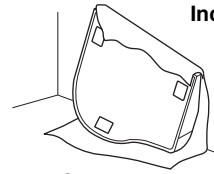

Incorrect

2. Attach the three legs and three leg beams.

Refer to the diagram below to verify the orientation of the legs.

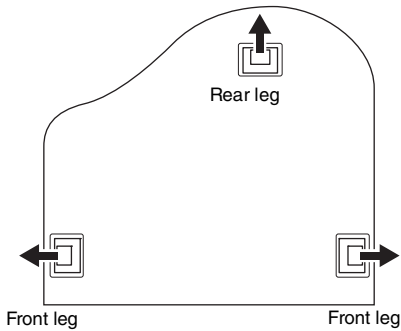

2-1. Install and tighten four screws on each leg, starting with one of the front legs.

6 × 40 mm fixing screws

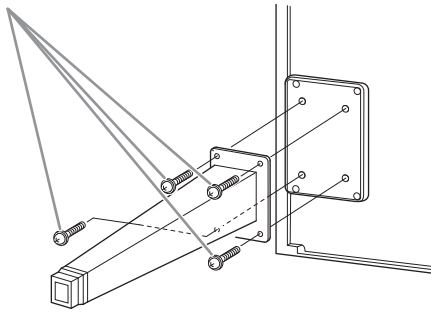

2-2. Slide the leg beams over the legs, and attach them to each of the legs using four thin screws (4 × 10 mm).

Make sure that the gradually inclined side of the leg beams faces the inside of the unit as shown.

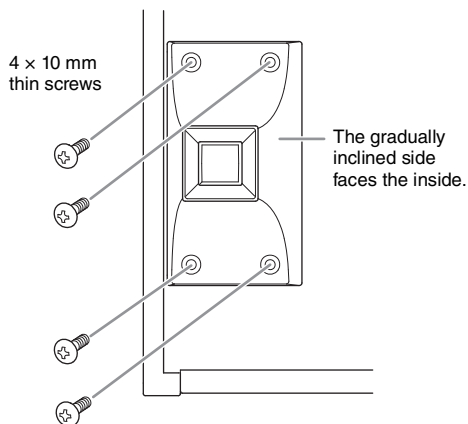

3. Attach the lyre braces.

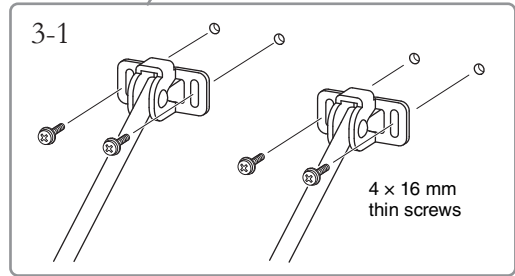
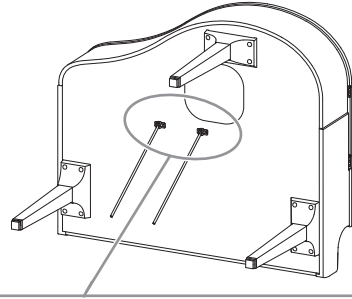

3-1. Attach the lyre braces using the four thin screws (4 × 16 mm).

4. Raise the unit to the standing position.

Use the front legs as support to raise the unit.

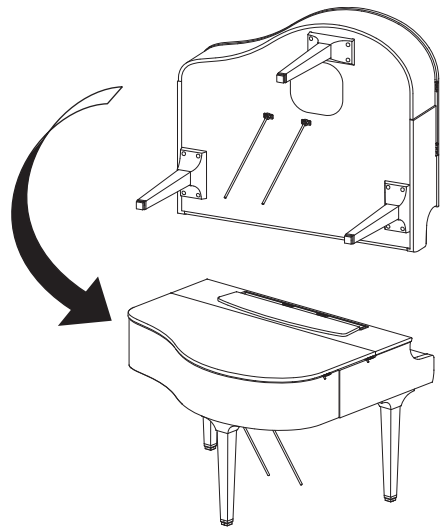

5. Install the pedal box.

- 5-1. Remove the twist tie and tape that affix the pedal cord to the upper portion of the pedal box.

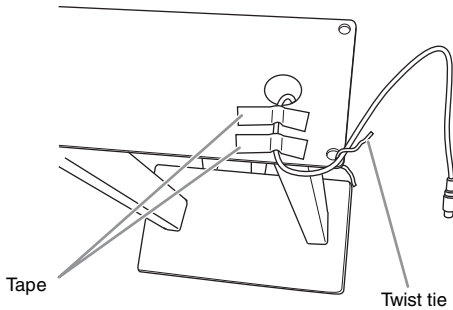

- 5-2. Attach the front side of the pedal box to the bottom of the unit by finger-tightening the two fixing screws (6 × 20 mm).

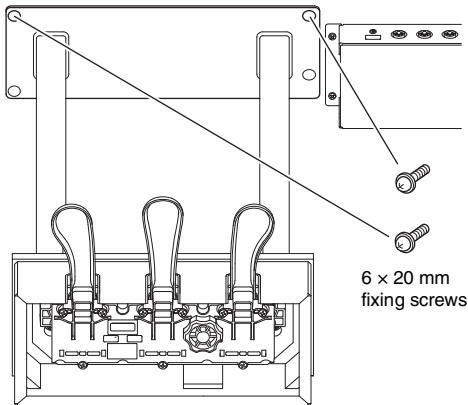

- 5-3. Insert the lyre braces into the pedal box recesses and make sure they fit securely.

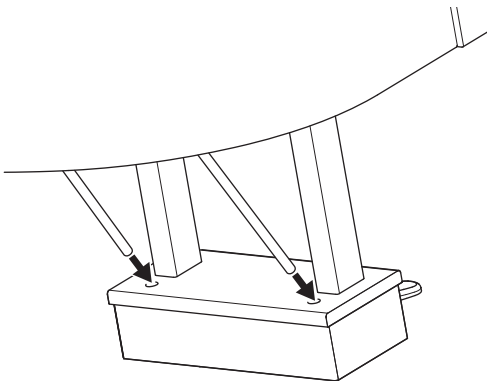

- 5-4. Align the cord with the groove on the unit and attach the backside of the pedal box using the two fixing screws (6 × 20 mm), and then securely tighten the two screws of the front side of the pedal box that were attached in step 5-2.

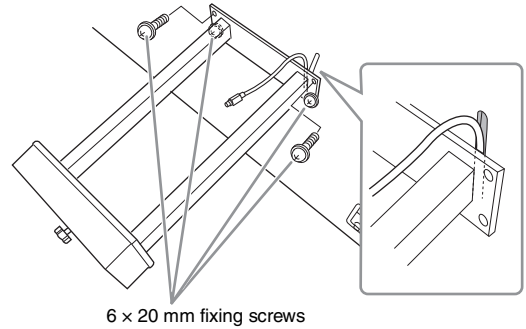

- 5-5. Loosen the four screws that were attached in step 3, and then securely tighten the four screws again while pushing the lyre braces in the direction of arrows as illustrated.

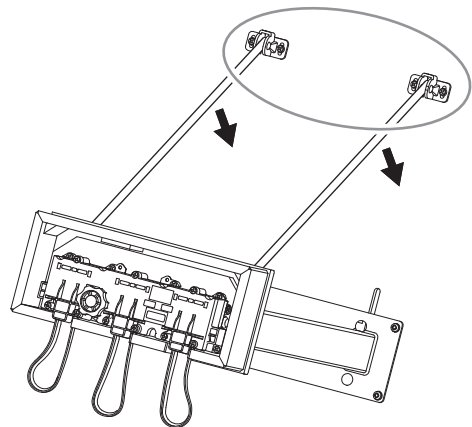

5-6. Insert the pedal cord plug into the pedal connector. Insert the plug so the arrow side faces front (toward the keyboard).

If the plug will not go in easily, do not force it. Double-check the orientation of the plug, then try again.

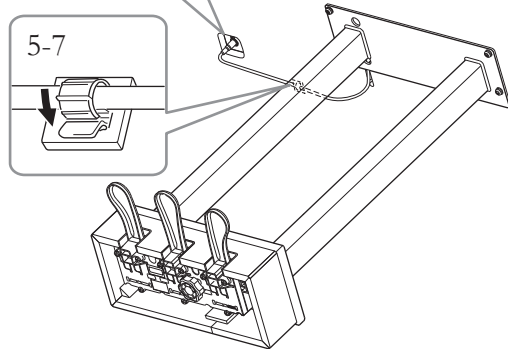
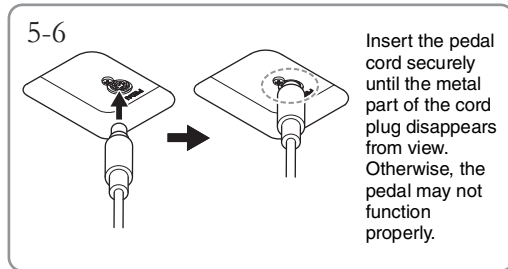

5-7. Attach the cord holder to the bottom of the main unit as shown, then clip the holder around the cord.

6. Insert the plug of the power cord into the AC IN jack.

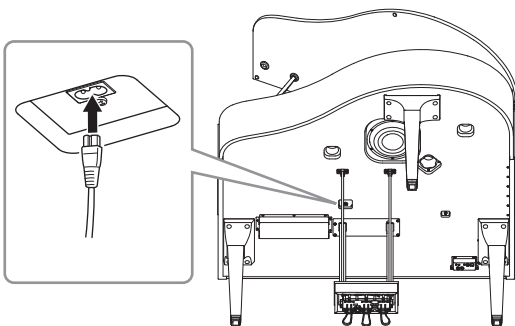

7. Rotate the adjuster until it comes in firm contact with the floor surface.

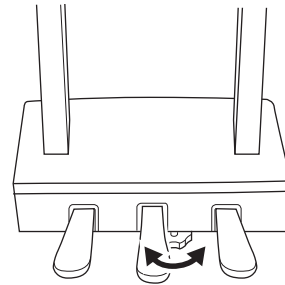

8. Attach the headphone hanger.

Attach the headphone hanger using two thin screws (4 × 10 mm) as shown in the illustration.

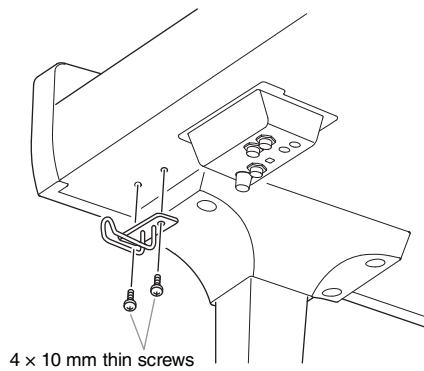

After completing the assembly, please check the following.

- **Are there any parts left over?**
→ Review the assembly procedure and correct any errors.
- **Is the instrument clear of doors and other movable fixtures?**
→ Move the instrument to an appropriate location.
- **Do the instrument or the music rest make a rattling noise when you shake it?**
→ Tighten all screws.
- **Does the pedal box rattle or give way when you step on the pedals?**
→ Turn the adjuster so that it is set firmly against the floor.
- **Are the pedal and power cords inserted securely into the sockets?**
→ Check the connection.

CAUTION

If the unit or the music rest creak or is otherwise unsteady when you play on the keyboard, refer to the assembly diagrams and retighten all screws.

CSP-275/CSP-255 Assembly

The illustrations as shown here are based on the CSP-275.

⚠ CAUTION

- Assembly should be carried out by at least two persons.
- Assemble the unit on a hard and flat floor with ample space.
- Be careful not to confuse parts, and be sure to install all parts in the correct orientation. Please assemble the unit in accordance with the sequence given below.
- Be sure to use only the included screws of the specified sizes. Do not use any other screws. Use of incorrect screws can cause damage or malfunction of the product.
- Be sure to tighten all screws upon completing assembly of the unit.
- To disassemble the unit, reverse the assembly sequence given below.

Have a Phillips-head (+) screwdriver of the appropriate size ready.

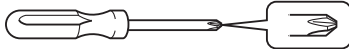

Remove all parts from the package and make sure you have all of the items.

Remove polystyrene foam pads from the package, position them on the floor, then place A on top of them. Position the pads so that they will not block the speaker box or connector on the bottom of A.

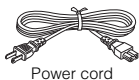
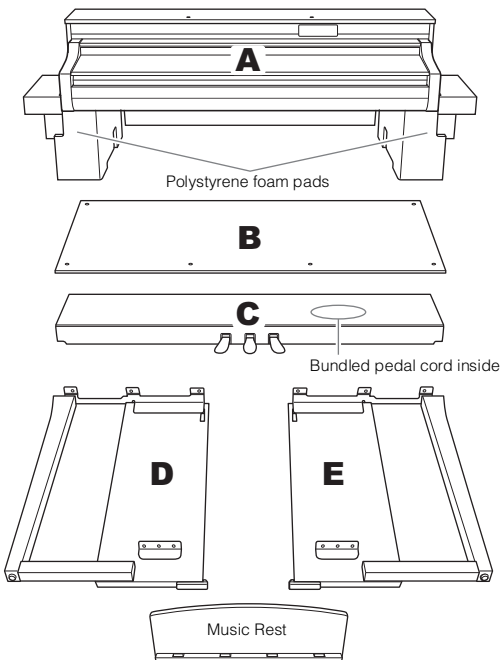

CSP-275B / CSP-275PE
CSP-255B / CSP-255PE

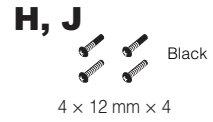
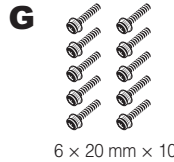

CSP-275WH
CSP-255WH

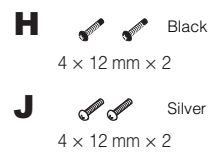

1 Attach C to D and E.

- 1 Untie and straighten out the bundled pedal cord. Do not discard the vinyl tie. You will need it later in step 5.

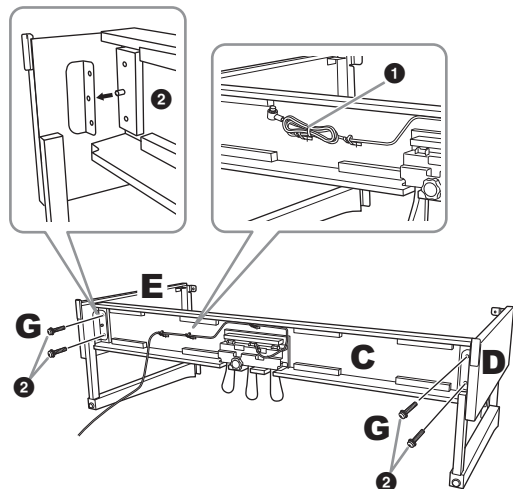

- 2 Insert the protrusions into the holes on the brackets, then attach D and E to C by tightening G (x 4).

2 Attach B.

Depending on the model of digital piano you purchased, the surface color of one side of B may be different from the other side. If so, position B so that the side similar in color to D and E faces the player.

- Align the screw holes on the upper side of B with the bracket holes on D and E, then attach the upper corners of B to D and E by finger-tightening H (× 2).

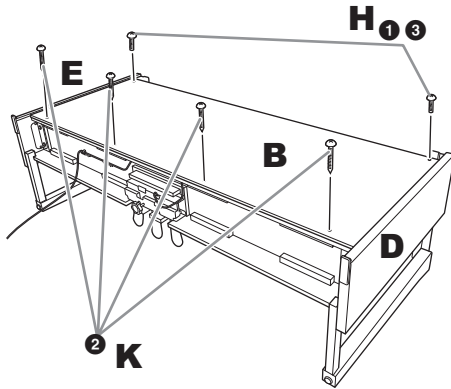

- Secure the bottom end of B using K (× 4).
- Securely tighten H on the top of B that were attached in Step 2-1.

3 Mount A.

Be sure to place your hands at least 15 cm away from either end of the bottom of A when positioning it.

Align the screw holes.

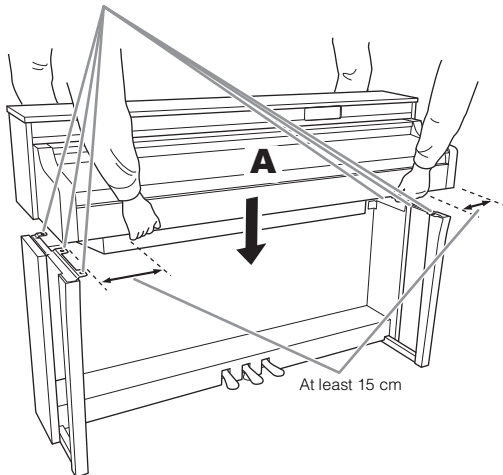

CAUTION

Be extremely careful not to drop the main unit or let your fingers be pinched by it. Do not hold A in any position other than the position specified above.

4 Secure A.

- Adjust the position of A so that the left and right ends of A will project beyond D and E equally (as seen from the front).

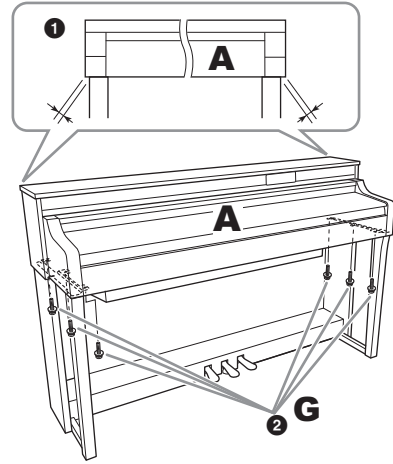

- Secure A by tightening G (× 6) from the front.

5 Connect the pedal cord and power cord.

- Insert the plug of the pedal cord into the [PEDAL] jack.

Insert the pedal cord securely until the metal part of the cord plug disappears from view. Otherwise, the pedal may not function properly.

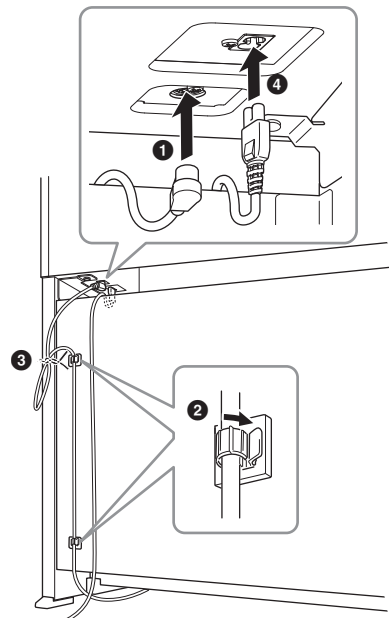
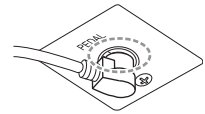

- Attach the cord holders to the rear panel as shown, then clip the cord into the holders.

- ③ Use a vinyl tie to take up any slack in the pedal cord.
- ④ Insert the plug of the power cord into the AC IN jack.

6 Set the adjuster.

Rotate the adjuster until it comes in firm contact with the floor surface.

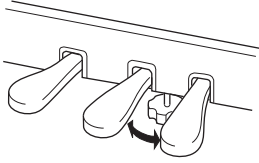

7 Attach the headphone hanger.

Use L (× 2) to attach the hanger as shown in the illustration.

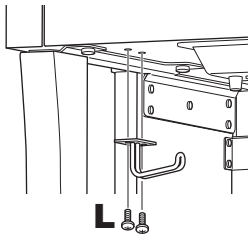

8 Attach the Music Rest to A.

- ① Finger-tighten J (× 2) as shown in the illustration.

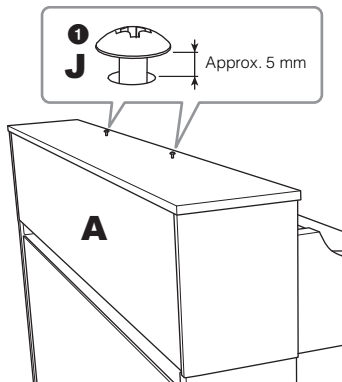

- ② Install the brackets of the Music Rest onto J, and slide them so that J fit into the smaller ends of the keyhole slots.

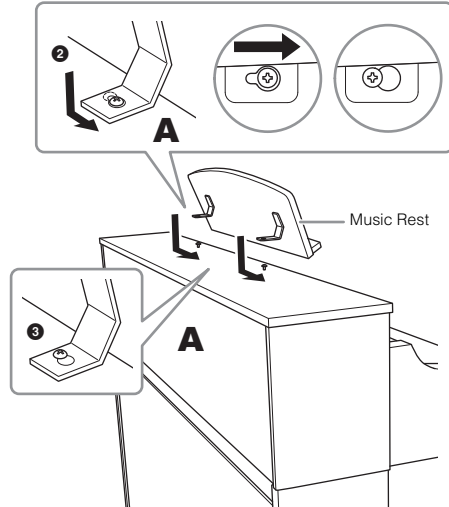

- ③ Fully tighten J.

After completing the assembly, please check the following.

- **Are there any parts left over?**
→ Review the assembly procedure and correct any errors.
- **Is the instrument clear of doors and other movable fixtures?**
→ Move the instrument to an appropriate location.
- **Do the instrument or the music rest make a rattling noise when you shake it?**
→ Tighten all screws.
- **Does the pedal box rattle or give way when you step on the pedals?**
→ Turn the adjuster so that it is set firmly against the floor.
- **Are the pedal and power cords inserted securely into the sockets?**
→ Check the connection.

⚠ CAUTION

If the unit or the music rest creak or is otherwise unsteady when you play on the keyboard, refer to the assembly diagrams and retighten all screws.

Troubleshooting

Problem	Possible Cause and Solution
The instrument does not turn on.	The instrument has not been plugged in properly. Securely insert the female plug into the socket on the instrument, and the male plug into a proper AC outlet (page 19).
The power is automatically turned off.	This is normal and due to the Auto Power Off function. If necessary, set the parameter of the Auto Power Off function (page 20).
Noise is heard from the speakers or headphones.	The noise may be due to interference caused by the use of a mobile phone in close proximity to the instrument. Turn off the mobile phone, or use it further away from the instrument.
Noise is heard from the instrument's speakers or headphones when using the instrument with the smart device.	When you use the instrument along with your smart device, we recommend that you connect with a cable, or set your device to not emit radio waves (such as with "Airplane Mode"), turn on Bluetooth/Wi-Fi only, and connect to the instrument.
The overall volume is low, or no sound is heard.	The Master Volume is set too low; set it to an appropriate level using the [MASTER VOLUME] slider (page 21).
	A plug is connected to the [PHONES] jack. Unplug the headphones or adaptor plug.
Pedals do not function.	The pedal cord may not be securely connected to the [PEDAL] jack. Be sure to insert the pedal cord all the way until the metal part of the cord plug disappears from view (page 49).
The keyboard volume is lower than the metronome volume.	The volume level for the metronome is set too loud. Adjust the metronome volume (page 34).
Higher or lower notes do not sound correctly when the transpose or octave setting is made.	The instrument can cover a key range of C-2 – G8 when you set the transposition. If notes lower than C-2 are played, the actual resulting sound is one octave higher. If notes higher than G8 are played, the resulting sound is one octave lower.
The sound output from the external speaker or the sound of Song playback recorded in audio format is not the usual.	This is because the "Binaural" setting is turned on. When "Binaural" is on and headphones are connected, the VRM Voices (including the sound outside the headphones) automatically change to the sound of Binaural Sampling or the sound enhanced with the Stereophonic Optimizer. This is turned on by default. You can turn it on or off from [Utility] → [Sound Setting] → [Binaural] of Smart Pianist.
Three lines of Stream Lights continues flashing in red.	Communication with the USB wireless LAN adaptor has been shut down because of the overcurrent to the USB wireless LAN adaptor. Disconnect the device from the [USB TO DEVICE] terminal, and then turn off the power of the instrument and turn it on again.
One line of Stream Lights flashes in red and stops.	A USB device that cannot be used is connected to the [USB-C] or [USB TO DEVICE] terminal. A smart device or a computer can be connected to the [USB-C] terminal (pages 29, 39). For the devices that can be connected to the [USB TO DEVICE] terminal, refer to page 27.

*For information on the functions and operations of Smart Pianist, see the Help within the app.

Specifications

Specifications of the instrument

		CSP-295GP	CSP-295	CSP-275	CSP-255	
Product Name		Digital Piano				
Size/Weight	Width [For models with polished finish]	[1,430 mm (56-5/16")]	1,437 mm (56-9/16") [1,437 mm (56-9/16")]	1,412 mm (55-9/16") [1,418 mm (55-13/16")]		
	Height [For models with polished finish]	With music rest closed	[931 mm (36-5/8")]	1,127 mm (44-3/8") [1,129 mm (44-7/16")]	1,041 mm (41") [1,041 mm (41")]	
		With music rest raised	[1,093 mm (43-1/16")]			
		With lid up	[1,580 mm (62-3/16")]	-		
	Depth [For models with polished finish]	[1,237 mm (48-11/16")]	484 mm (19-1/16") [484 mm (19-1/16")]	465 mm (18-5/16") [466 mm (18-3/8")]		
Weight [For models with polished finish]	[133 kg (293 lb, 3 oz)]	99 kg (218 lb, 4 oz) [Black: 103 kg (227 lb, 1 oz)/ White: 104 kg (229 lb, 4 oz)]	67 kg (147 lb, 11 oz) [69 kg (152 lb, 2 oz)]	58 kg (127 lb, 14 oz) [61 kg (134 lb, 8 oz)]		
Control Interface	Keyboard	Number of Keys	88			
		Type	GrandTouch Keyboard: wooden keys (white only), synthetic ebony and ivory key tops, escapement	GrandTouch-S Keyboard: wooden keys (white only), synthetic ebony and ivory key tops, escapement	GrandTouch-S Keyboard: synthetic ebony and ivory key tops, escapement	
		88-key Linear Graded Hammers	Yes	-		
		Counter weight	Yes	-		
		Touch Sensitivity	Soft2/Soft1/Medium/Hard1/Hard2/Fixed			
	Pedal	Number of Pedals	3: Damper (with Half-pedal function), Sostenuto, Soft			
		GrandTouch Pedals	Yes	-		
GP Response Damper		Yes	-			
Panel	Language	English				
Cabinet	Key Cover Style	Sliding	Folding	Sliding		
	Music Rest	Yes (with music clips)				
Functions	Bluetooth (May not have this functionality depending on the country in which you purchased the product.)	Audio	Supported profile: A2DP, Compatible codec: SBC			
		MIDI	Comply with Bluetooth Low Energy MIDI Specification			
		Bluetooth version	5.0			
		Wireless output	Bluetooth Class 2			
		Maximum communication distance	Approx. 10 m			
		Radio Frequency	2,401 – 2,481 MHz			
		Maximum output power (EIRP)	4 dBm			
Type of modulation	FHSS					

		CSP-295GP	CSP-295	CSP-275	CSP-255
Functions	USB Audio Interface	44.1 kHz, 24 bit, stereo			
	Lesson/Guide	Yes (with Stream Lights)			
Voices	Tone Generation	Piano Sound	Yamaha CFX, Bösendorfer Imperial		
		Binaural Sampling	Yes ("CFX Grand" and "Bösendorfer" only)		
	Piano Effects	VRM (Virtual Resonance Modeling)	Yes		
		Grand Expression Modeling	Yes		
		Key-off Samples	Yes		
		Smooth Release	Yes		
	Polyphony (max.)	256			
	Compatibility (for Song playback)	XG, GS, GM, GM2			
Connectivity	Headphones	Standard stereo phone jack (x 2)			
	Microphone	Mic/Line In (standard mono phone jack), input volume			
	MIDI	IN, OUT, THRU			
	AUX IN	Stereo Mini jack			
	AUX OUT	Standard phone jack (R, L/L+R)			
	AUX PEDAL	Yes			
	USB TO DEVICE	Yes			
	USB-C	Yes			
Sound System	Amplifiers	(50 W + 50 W + 40 W) × 2	(50 W + 50 W + 40 W) × 2	(50 W + 50 W) × 2	40 W × 2
	Speakers	(16 cm + 8 cm + 2.5 cm (dome) with Waveguide) × 2 + 20 cm, Spruce Cone Speaker, Twisted Flare Port	(16 cm + 8 cm + 2.5 cm (dome) with Bidirectional Horn) × 2, Spruce Cone Speaker	(16 cm + 8 cm) × 2	16 cm × 2
Power Supply	Auto Power Off	Yes			
Included Accessories	Owner's Manual, Online Member Product Registration, power cord, bench*, headphone hanger and attachment screws *May not be included depending on your area. Check with your Yamaha dealer.				

Separately Sold Accessories

- *May not be available depending on your area.
- Headphones HPH-150, HPH-100, HPH-50
- Footswitch FC5, FC4A
- Foot controller FC7
- USB wireless LAN adaptor UD-WL01

Compatible formats for this instrument

■ GM2

"GM (General MIDI)" is one of the most common Voice allocation formats. "GM System Level 2" is a standard specification that enhances the original "GM" and improves Song data compatibility. It provides for increased polyphony, greater Voice selection, expanded Voice parameters, and integrated effect processing.

■ XG

XG is a major enhancement of the GM System Level 1 format, and was developed by Yamaha specifically to provide more Voices and variations, as well as greater expressive control over Voices and effects, and to ensure compatibility of data well into the future.

■ GS

GS was developed by the Roland Corporation. In the same way as Yamaha XG, GS is a major enhancement of the GM specifically to provide more Voices and Drum kits and their variations, as well as greater expressive control over Voices and effects.

■ XF

The Yamaha XF format enhances the SMF (Standard MIDI File) standard with greater functionality and open-ended expandability for the future. This instrument is capable of displaying lyrics when an XF file containing lyric data is played.

What you can do with the instrument stand-alone and when connected with Smart Pianist

		Instrument only	Instrument + Smart Pianist
Language		English	Menu: English/German/French/Spanish/Japanese/Chinese Messages and Help: 26 languages
Piano Room (various settings for piano sound)		–	Yes
Voices	Number of Voices	10	CSP-295GP/CSP-295: 919, CSP-275/CSP-255: 819
	Layer (layering two Voices)	–	Yes
	Left (playing two different Voices by right- and left-hand)	–	Yes
	Split Point Change	–	Yes
	Octave	–	Yes
Styles	Number of Styles	10	CSP-295GP/CSP-295: 525, CSP-275/CSP-255: 495
	Chord Detection Area	Full (cannot be changed)	Full/Lower
	Intro/Ending	On (cannot be changed)	On/Off
	Section Change	–	Main × 4
	Synchro Start	–	Yes
	Playback Parts	All/Rhythm&Bass/Rhythm	8 Parts, independent on/off control
Effects	Reverb Types	5 types	65 types
Recording	MIDI	–	Yes (SMF format 0)
	Audio	–	Yes (WAV, AAC) *Recordable only via the USB cable or Wi-Fi connection.
Songs	Number of Songs for playback	10	403
	Stream Lights Setting	On (cannot be changed)	On/Off, Speed
	Guide Type	Correct Key (cannot be changed)	Correct Key/Any Key/Karao-key/ Your Tempo
	Score/Chord/Lyrics Display Function	–	Yes
	Audio To Score	–	Yes
	A-B Repeat	–	Yes
Registration Memory		–	Yes
Metronome		Yes	
Tempo		5 – 500, Tap Tempo	
Balance (volume balance among parts)		–	Yes
Utility	Transpose	Keyboard	Keyboard/Style, Song
	Tuning	414.8 – 440.0 – 466.8 Hz (0.2 Hz increments)	414.8 – 440.0 – 466.8 Hz (0.2 Hz increments), 9 scale types
	Keyboard Setting (Touch Curve)	Soft2/Soft1/Medium/Hard1/Hard2/Fixed	
	Pedal Setting	–	Yes (functions can be selected)
	Mic Setting	–	Yes (Vocal Harmony, etc.)
	Master EQ	–	Yes
	Sound Setting	–	Yes (Binaural, IAC, etc.)
	Auto Power Off	Disabled/Enabled	Disabled/Enabled (elapsed time can be set)

There are many more parameters that can be set on Smart Pianist. Check and try them out on the app.

The contents of this manual apply to the latest specifications as of the publishing date. To obtain the latest manual, access the Yamaha website then download the manual file. Since specifications, equipment or separately sold accessories may not be the same in every locale, please check with your Yamaha dealer.

Index

A

Accompaniment	33
App	24
Assembly (CSP-275/CSP-255)	48
Assembly (CSP-295GP)	44
Audio device	40
Audio Loopback	37
Auto Power Off	20

B

Backup data	20
Binaural Sampling	23
Bluetooth	25

C

Computer	39
Connection (external devices)	39
Connection (Smart Pianist)	24

F

Foot controller	41
Footswitch	41
Function List	30

G

GP Response Damper (CSP-295GP/CSP-295)	22
Grand Expression Modeling	20
Guitar	42

H

Half-pedal	21
Headphone hanger	22
Headphones	22

I

IAC (Intelligent Acoustic Control)	21
Initialize	38

K

Key cover	15
-----------------	----

L

Lid	18
-----------	----

M

Metronome	34
Microphone	42
MIDI device	43

MIDI transmit channel	37
Music braces	16
Music rest	16

P

Pedal	21
Pitch	36
Power	19

R

Reverb	35
--------------	----

S

Smart Pianist	24
Song	32
Song List	31
Stereophonic Optimizer	23
Style	33
Style List	31

T

Tempo	34
Touch Sensitivity	35
Transpose	36
Tuning	36

U

USB Audio Interface	40
---------------------------	----

V

Voice	32
Voice List	30
Volume (master volume)	21
Volume (metronome)	34
VRM	23

W

Wi-Fi	27
-------------	----

Credits and Copyrights for the pre-installed Songs

All I Want For Christmas Is You

Words and Music by Mariah Carey and Walter Afanasieff

Copyright © 1994 UNIVERSAL TUNES, BEYONDIDOLIZATION, SONY/ATV MUSIC PUBLISHING LLC, TAMAL VISTA MUSIC and KOBALT MUSIC COPYRIGHTS SARL

All Rights for BEYONDIDOLIZATION Administered by UNIVERSAL TUNES

All Rights for SONY/ATV MUSIC PUBLISHING LLC and TAMAL VISTA MUSIC

Administered by SONY/ATV MUSIC PUBLISHING LLC, 424 Church Street, Suite 1200, Nashville, TN 37219

All Rights for KOBALT MUSIC COPYRIGHTS SARL Administered Worldwide by KOBALT SONGS MUSIC PUBLISHING

All Rights Reserved Used by Permission

All The Things You Are

Lyrics by Oscar Hammerstein II

Music by Jerome Kern

Copyright © 1939 UNIVERSAL - POLYGRAM INTERNATIONAL PUBLISHING, INC.

Copyright Renewed

All Rights Reserved Used by Permission

Autumn Leaves

English lyric by Johnny Mercer

French lyric by Jacques Prevert

Music by Joseph Kosma

© 1947, 1950 (Renewed) ENOCH ET CIE

Sole Selling Agent for U.S. and Canada:

MORLEY MUSIC CO., by agreement with ENOCH ET CIE

All Rights Reserved

Back For Good

Words and Music by Gary Barlow

Copyright © 1995 Sony/ATV Music Publishing (UK) Limited

All Rights Administered by Sony/ATV Music Publishing LLC, 424 Church Street, Suite 1200, Nashville, TN 37219

International Copyright Secured All Rights Reserved

Billie Jean

Words and Music by Michael Jackson

Copyright © 1982 Mijac Music

All Rights Administered by Sony/ATV Music Publishing LLC, 424 Church Street, Suite 1200, Nashville, TN 37219

International Copyright Secured All Rights Reserved

Can't Take My Eyes Off Of You

Words and Music by Bob Crewe and Bob Gaudio

Copyright © 1967 EMI Longitude Music and Seasons Four Music

Copyright Renewed

All Rights on behalf of EMI Longitude Music Administered by Sony/ATV Music Publishing LLC, 424 Church Street, Suite 1200, Nashville, TN 37219

International Copyright Secured All Rights Reserved

Candle In The Wind

Words and Music by Elton John and Bernie Taupin

Copyright © 1973 UNIVERSAL/DICK JAMES MUSIC LTD.

Copyright Renewed

All Rights in the United States and Canada Controlled and Administered by UNIVERSAL

- SONGS OF POLYGRAM

INTERNATIONAL, INC.

All Rights Reserved Used by Permission

Clocks

Words and Music by Guy Berryman, Jon

Buckland, Will Champion and Chris Martin

Copyright © 2002 by Universal Music

Publishing MGB Ltd.

All Rights in the United States Administered by

Universal Music - MGB Songs

International Copyright Secured All Rights Reserved

Dancing Queen

Words and Music by Benny Andersson, Bjorn

Ulvaeus and Stig Anderson

Copyright © 1976, 1977 UNIVERSAL/UNION

SONGS MUSIKFORLAG AB

Copyright Renewed

All Rights Administered by UNIVERSAL -

POLYGRAM INTERNATIONAL

PUBLISHING, INC. and EMI GROVE

PARK MUSIC, INC.

All Rights Reserved Used by Permission

Eternal Flame

Words and Music by Billy Steinberg, Tom Kelly and Susanna Hoffs

Copyright © 1988 Sony/ATV Music Publishing LLC and Bangophile Music

All Rights on behalf of Sony/ATV Music

Publishing LLC Administered by Sony/ATV

Music Publishing LLC, 424 Church Street,

Suite 1200, Nashville, TN 37219

All Rights on behalf of Bangophile Music

Controlled and Administered by Songs Of

Universal, Inc.

International Copyright Secured All Rights

Reserved

Every Breath You Take

Music and Lyrics by Sting

Copyright © 1983 G.M. Sumner

All Rights Administered by Sony/ATV Music

Publishing LLC, 424 Church Street, Suite

1200, Nashville, TN 37219

International Copyright Secured All Rights

Reserved

Fields Of Gold

Music and Lyrics by Sting

Copyright © 1993 Steerpikie Ltd.

All Rights Administered by Sony/ATV Music

Publishing LLC, 424 Church Street, Suite

1200, Nashville, TN 37219

International Copyright Secured All Rights

Reserved

Final Countdown

Words and Music by Joey Tempest

Copyright © 1986 EMI Music Publishing Ltd.

All Rights Administered by Sony/ATV Music

Publishing LLC, 424 Church Street, Suite

1200, Nashville, TN 37219

International Copyright Secured All Rights

Reserved

The Girl From Ipanema (Garôta De Ipanema)

Music by Antonio Carlos Jobim

English Words by Norman Gimbel

Original Words by Vinicius De Moraes

Copyright © 1963 ANTONIO CARLOS JOBIM

and VINICIUS DE MORAES, Brazil

Copyright Renewed 1991 and Assigned to

SONGS OF UNIVERSAL, INC. and

WORDS WEST LLC

English Words Renewed 1991 by NORMAN

GIMBEL for the World and Assigned to

WORDS WEST LLC (P.O. Box 15187,

Beverly Hills, CA 90209 USA)

All Rights Reserved Used by Permission

Hallelujah

Words and Music by Leonard Cohen

Copyright © 1985 Sony/ATV Music Publishing LLC

All Rights Administered by Sony/ATV Music

Publishing LLC, 424 Church Street, Suite

1200, Nashville, TN 37219

International Copyright Secured All Rights

Reserved

Hey Jude

Words and Music by John Lennon and Paul

McCartney

Copyright © 1968 Sony/ATV Music Publishing

LLC

Copyright Renewed

All Rights Administered by Sony/ATV Music

Publishing LLC, 424 Church Street, Suite

1200, Nashville, TN 37219

International Copyright Secured All Rights

Reserved

I Will Always Love You

Words and Music by Dolly Parton

Copyright © 1973 Velvet Apple Music

Copyright Renewed

All Rights Administered by Sony/ATV Music

Publishing LLC, 424 Church Street, Suite

1200, Nashville, TN 37219

International Copyright Secured All Rights

Reserved

In The Mood

By Joe Garland

Copyright © 1939, 1960 Shapiro, Bernstein & Co., Inc., New York

Copyright Renewed

International Copyright Secured All Rights

Reserved

Used by Permission

Into The Unknown

from FROZEN 2

Music and Lyrics by Kristen Anderson-Lopez and Robert Lopez

© 2019 Wonderland Music Company, Inc.

All Rights Reserved. Used by Permission.

Just The Way You Are

Words and Music by Billy Joel

Copyright © 1977 ALMO MUSIC CORP. and IMPULSIVE MUSIC

Copyright Renewed

All Rights Administered by ALMO MUSIC

CORP

All Rights Reserved Used by Permission

La Bamba

By Richard Valenzuela

Copyright © 1959 EMI Longitude Music and Valens Heirs Designee

Copyright Renewed

All Rights Administered by Sony/ATV Music

Publishing LLC, 424 Church Street, Suite

1200, Nashville, TN 37219

International Copyright Secured All Rights

Reserved

Let There Be Love

Lyric by Ian Grant

Music by Lionel Rand

Copyright © 1940 Shapiro, Bernstein & Co., Inc., New York

Copyright Renewed

International Copyright Secured All Rights

Reserved Used by Permission

Lover

Words and Music by Taylor Swift
 Copyright © 2019 Sony/ATV Music Publishing
 LLC and Taylor Swift Music
 All Rights Administered by Sony/ATV Music
 Publishing LLC, 424 Church Street, Suite
 1200, Nashville, TN 37219
 International Copyright Secured All Rights
 Reserved

Moon River

from the Paramount Picture BREAKFAST AT
 TIFFANY'S
 Words by Johnny Mercer
 Music by Henry Mancini
 Copyright © 1961 Sony/ATV Music Publishing
 LLC
 Copyright Renewed
 All Rights Administered by Sony/ATV Music
 Publishing LLC, 424 Church Street, Suite
 1200, Nashville, TN 37219
 International Copyright Secured All Rights
 Reserved

**My Heart Will Go On (Love Theme From
'Titanic')**

from the Paramount and Twentieth Century
 Fox Motion Picture TITANIC
 Music by James Horner
 Lyric by Will Jennings
 Copyright © 1997 Sony/ATV Harmony, Sony/
 ATV Melody, T C F Music Publishing, Inc.,
 Fox Film Music Corporation and Blue Sky
 Rider Songs
 All Rights on behalf of Sony/ATV Harmony and
 Sony/ATV Melody Administered by Sony/
 ATV Music Publishing LLC, 424 Church
 Street, Suite 1200, Nashville, TN 37219
 All Rights on behalf of Blue Sky Rider Songs
 Administered by Irving Music, Inc.
 International Copyright Secured All Rights
 Reserved

Poker Face

Words and Music by Stefani Germanotta and
 RedOne
 Copyright © 2008 Sony/ATV Music Publishing
 LLC, House Of Gaga Publishing Inc. and
 RedOne Productions, LLC
 All Rights Administered by Sony/ATV Music
 Publishing LLC, 424 Church Street, Suite
 1200, Nashville, TN 37219
 International Copyright Secured All Rights
 Reserved

Señorita

Words and Music by Camila Cabello, Charlotte
 Aitchison, Jack Patterson, Shawn Mendes,
 Magnus Hoiberg, Benjamin Levin, Ali
 Tamposi and Andrew Wotman
 Copyright © 2019 Maidmetal Limited,
 Milamoon Songs, Stellar Songs Ltd., EMI
 Music Publishing Ltd., Songs Of Universal,
 Inc., Mendes Music, Infinite Stripes, Back
 Hair Music Publishing, Universal Music
 Works, Please Don't Forget To Pay Me Music,
 Reservoir 416 and Andrew Watt Music
 All Rights on behalf of Maidmetal Limited,
 Milamoon Songs, Stellar Songs Ltd. and EMI
 Music Publishing Ltd. Administered by
 Sony/ATV Music Publishing LLC, 424
 Church Street, Suite 1200, Nashville,
 TN 37219
 All Rights on behalf of Mendes Music, Infinite
 Stripes and Back Hair Music Publishing
 Administered by Songs Of Universal, Inc.
 All Rights on behalf of Please Don't Forget To
 Pay Me Music Administered by Universal
 Music Works

All Rights on behalf of Reservoir 416
 Administered Worldwide by Reservoir
 Media Management, Inc.
 All Rights on behalf of Andrew Watt Music
 Administered Worldwide by Songs Of Kobalt
 Music Publishing
 International Copyright Secured All Rights
 Reserved

Shallow

from A STAR IS BORN
 Words and Music by Stefani Germanotta, Mark
 Ronson, Andrew Wyatt and Anthony
 Rossomando
 Copyright © 2018 Sony/ATV Music Publishing
 LLC, SG Songs Worldwide, Concord
 Copyrights, Songs Of Zelig, Downtown
 DMP Songs, Downtown DJL Songs,
 Stephaniesays Music, White Bull Music
 Group, Warner-Barham Music, LLC and
 Warner-Olive Music, LLC
 All Rights on behalf of Sony/ATV Music
 Publishing LLC and SG Songs Worldwide
 Administered by Sony/ATV Music
 Publishing LLC, 424 Church Street, Suite
 1200, Nashville, TN 37219
 All Rights on behalf of Songs Of Zelig
 Administered by Concord Copyrights
 All Rights on behalf of Downtown DMP Songs,
 Downtown DJL Songs, Stephaniesays Music
 and White Bull Music Group Administered
 by Downtown Music Publishing LLC
 All Rights (Excluding Print) on behalf of
 Warner-Barham Music, LLC Administered
 by Songs Of Universal, Inc.
 All Rights (Excluding Print) on behalf of
 Warner-Olive Music, LLC Administered by
 Universal Music Corp.
 Exclusive Worldwide Print Rights on behalf of
 Warner-Barham Music, LLC and Warner-
 Olive Music, LLC Administered by Alfred
 Music

International Copyright Secured All Rights
 Reserved

Spanish Eyes

Words by Charles Singleton and Eddie Snyder
 Music by Bert Kaempfert
 Copyright © 1965 Bert Kaempfert Music
 Copyright Renewed
 All Rights Administered by Sony/ATV Music
 Publishing LLC, 424 Church Street, Suite
 1200, Nashville, TN 37219
 International Copyright Secured All Rights
 Reserved

10,000 Hours

Words and Music by Dan Smyers, Jordan
 Reynolds, Shay Mooney, Justin Bieber, Jason
 Boyd and Jessie Jo Dillon
 © 2019 WC MUSIC CORP., BEATS AND
 BANJOS, BUCKEYE26, JREYNMUSIC,
 WARNER-TAMERLANE PUBLISHING
 CORP., SHAY MOONEY MUSIC,
 UNIVERSAL MUSIC CORP., BIEBER TIME
 PUBLISHING, BMG GOLD SONGS, POO
 BZ PUBLISHING INC., BIG MUSIC
 MACHINE and BIG ASS PILE OF DIMES
 MUSIC
 All Rights for BEATS AND BANJOS,
 BUCKEYE26 and JREYNMUSIC
 Administered by WC MUSIC CORP.
 All Rights for SHAY MOONEY MUSIC
 Administered by WARNER-TAMERLANE
 PUBLISHING CORP.
 All Rights for BIEBER TIME PUBLISHING
 Administered by UNIVERSAL MUSIC
 CORP. All Rights for BMG GOLD SONGS
 and POO BZ PUBLISHING INC.
 Administered by BMG RIGHTS
 MANAGEMENT (US) LLC

All Rights Reserved Used by Permission

Unchained Melody

Lyric by Hy Zaret
 Music by Alex North
 © 1955 (Renewed) North Melody Publishing
 (SESAC) and HZUM Publishing (SESAC) /
 o Unchained Melody Publishing, LLC
 All Rights Reserved Used by Permission

Up Where We Belong

from the Paramount Picture AN OFFICER
 AND A GENTLEMAN
 Words by Will Jennings
 Music by Buffy Sainte-Marie and Jack Nitzsche
 Copyright © 1982 Sony/ATV Music Publishing
 LLC
 All Rights Administered by Sony/ATV Music
 Publishing LLC, 424 Church Street, Suite
 1200, Nashville, TN 37219
 International Copyright Secured All Rights
 Reserved

What A Wonderful World

Words and Music by George David Weiss and
 Bob Thiele
 Copyright © 1967 by Range Road Music Inc.,
 Quartet Music and Abilene Music Copyright
 Renewed
 All Rights for Range Road Music Inc.
 Administered by Round Hill Carlin, LLC
 All Rights for Quartet Music Administered by
 BMG Rights Management (US) LLC
 All Rights for Abilene Music Administered by
 Concord Sounds c/o Concord Music
 Publishing
 International Copyright Secured All Rights
 Reserved Used by Permission

White Christmas

from the Motion Picture Irving Berlin's
 HOLIDAY INN
 Words and Music by Irving Berlin
 © Copyright 1940, 1942 by Irving Berlin
 Copyright Renewed
 International Copyright Secured All Rights
 Reserved

Wonderful Tonight

Words and Music by Eric Clapton
 Copyright © 1977 by Eric Patrick Clapton
 Copyright Renewed
 International Copyright Secured All Rights
 Reserved

Wonderwall

Words and Music by Noel Gallagher
 Copyright © 1995 SM Music Publishing UK
 Limited and Oasis Music
 All Rights Administered by Sony/ATV Music
 Publishing LLC, 424 Church Street, Suite
 1200, Nashville, TN 37219
 International Copyright Secured All Rights
 Reserved

You've Lost That Lovin' Feelin'

Words and Music by Barry Mann, Cynthia Weil
 and Phil Spector
 Copyright © 1964, 1965 Screen Gems-EMI
 Music Inc. and Mother Bertha Music
 Copyright Renewed
 All Rights Administered by Sony/ATV Music
 Publishing LLC, 424 Church Street, Suite
 1200, Nashville, TN 37219
 International Copyright Secured All Rights
 Reserved

For U.S.A.

This transmitter must not be co-located or operated in conjunction with any other antenna or transmitter.

(554-M01)

This equipment complies with FCC radiation exposure limits set forth for an uncontrolled environment and meets the FCC radio frequency (RF) Exposure Guidelines. This equipment has very low levels of RF energy that is deemed to comply without testing of specific absorption rate (SAR).

(554-M04)

For Canada

This device contains licence-exempt transmitter(s)/receiver(s) that comply with Innovation, Science and Economic Development Canada's licence-exempt RSS(s). Operation is subject to the following two conditions:

1. This device may not cause interference.
2. This device must accept any interference, including interference that may cause undesired operation of the device.

L'émetteur/récepteur exempt de licence contenu dans le présent appareil est conforme aux CNR d'Innovation, Sciences et Développement économique Canada applicables aux appareils radio exempts de licence. L'exploitation est autorisée aux deux conditions suivantes :

1. L'appareil ne doit pas produire de brouillage ;
2. L'appareil doit accepter tout brouillage radioélectrique subi, même si le brouillage est susceptible d'en compromettre le fonctionnement.

(555-M13 ISED RSS 01)

This equipment complies with ISED radiation exposure limits set forth for an uncontrolled environment and meets RSS-102 of the ISED radio frequency (RF) Exposure rules as this equipment has very low levels of RF energy.

Cet équipement est conforme aux limites d'exposition aux rayonnements énoncées pour un environnement non contrôlé et respecte les règles d'exposition aux fréquences radioélectriques (RF) CNR-102 de l'ISDE puisque cet appareil a une niveau tres bas d'energie RF.

(0555-M05_ised_portable_01)

For Mexico

La operación de este equipo está sujeta a las siguientes dos condiciones: (1) es posible que este equipo o dispositivo no cause interferencia perjudicial y (2) este equipo o dispositivo debe aceptar cualquier interferencia, incluyendo la que pueda causar su operación no deseada.

(556-M02 MX operating condition 01)

For European Union and United Kingdom

EN	SIMPLIFIED EU DECLARATION OF CONFORMITY / SIMPLIFIED UK DECLARATION OF CONFORMITY
<p>Hereby, Yamaha Music Europe GmbH declares that the radio equipment type [CSP-295GP, CSP-295, CSP-275, CSP-255] is in compliance with Directive 2014/53/EU and the radio equipment regulations of UK. The full texts of the EU declaration of conformity and the UK declaration of conformity are available at the following internet address: https://europe.yamaha.com/en/support/compliance/doc.html</p>	
FR	DECLARATION UE DE CONFORMITE SIMPLIFIEE
<p>Le soussigné, Yamaha Music Europe GmbH, déclare que l'équipement radioélectrique du type [CSP-295GP, CSP-295, CSP-275, CSP-255] est conforme à la directive 2014/53/UE. Le texte complet de la déclaration UE de conformité est disponible à l'adresse internet suivante : https://europe.yamaha.com/en/support/compliance/doc.html</p>	
DE	VEREINFACHTE EU-KONFORMITÄTSERKLÄRUNG
<p>Hiermit erklärt Yamaha Music Europe GmbH, dass der Funkanlagentyp [CSP-295GP, CSP-295, CSP-275, CSP-255] der Richtlinie 2014/53/EU entspricht. Der vollständige Text der EU-Konformitätserklärung ist unter der folgenden Internetadresse verfügbar: https://europe.yamaha.com/en/support/compliance/doc.html</p>	
SV	FÖRENKLAD EU-FÖRSÄKRAN OM ÖVERENSSTÄMMELSE
<p>Härmed försäkrar Yamaha Music Europe GmbH att denna typ av radioutrustning [CSP-295GP, CSP-295, CSP-275, CSP-255] överensstämmer med direktiv 2014/53/EU. Den fullständiga texten till EU-försäkrans om överensstämmelse finns på följande webbadress: https://europe.yamaha.com/en/support/compliance/doc.html</p>	
IT	DICHIARAZIONE DI CONFORMITÀ UE SEMPLIFICATA
<p>Il fabbricante, Yamaha Music Europe GmbH, dichiara che il tipo di apparecchiatura radio [CSP-295GP, CSP-295, CSP-275, CSP-255] è conforme alla direttiva 2014/53/UE. Il testo completo della dichiarazione di conformità UE è disponibile al seguente indirizzo Internet: https://europe.yamaha.com/en/support/compliance/doc.html</p>	
ES	DECLARACIÓN UE DE CONFORMIDAD SIMPLIFICADA
<p>Por la presente, Yamaha Music Europe GmbH declara que el tipo de equipo radioeléctrico [CSP-295GP, CSP-295, CSP-275, CSP-255] es conforme con la Directiva 2014/53/UE. El texto completo de la declaración UE de conformidad está disponible en la dirección Internet siguiente: https://europe.yamaha.com/en/support/compliance/doc.html</p>	
PT	DECLARAÇÃO UE DE CONFORMIDADE SIMPLIFICADA
<p>O(a) abaixo assinado(a) Yamaha Music Europe GmbH declara que o presente tipo de equipamento de rádio [CSP-295GP, CSP-295, CSP-275, CSP-255] está em conformidade com a Diretiva 2014/53/UE. O texto integral da declaração de conformidade está disponível no seguinte endereço de Internet: https://europe.yamaha.com/en/support/compliance/doc.html</p>	
NL	VEREENVOUDIGDE EU-CONFORMITEITSVERKLARING
<p>Hierbij verklaar ik, Yamaha Music Europe GmbH, dat het type radioapparatuur [CSP-295GP, CSP-295, CSP-275, CSP-255] conform is met Richtlijn 2014/53/EU. De volledige tekst van de EU-conformiteitsverklaring kan worden geraadpleegd op het volgende internetadres: https://europe.yamaha.com/en/support/compliance/doc.html</p>	
BG	ОПРОСТЕНА ЕС ДЕКЛАРАЦИЯ ЗА СЪОТВЕТСТВИЕ
<p>С настоящото Yamaha Music Europe GmbH декларира, че този тип радиосъоръжение [CSP-295GP, CSP-295, CSP-275, CSP-255] е в съответствие с Директива 2014/53/ЕС. Цялостният текст на ЕС декларацията за съответствие може да се намери на следния интернет адрес: https://europe.yamaha.com/en/support/compliance/doc.html</p>	
CS	ZJEDNODUŠENÉ EU PROHLÁŠENÍ O SHODĚ
<p>Tímto Yamaha Music Europe GmbH prohlašuje, že typ rádiového zařízení [CSP-295GP, CSP-295, CSP-275, CSP-255] je v souladu se směrnicí 2014/53/EU. Úplné znění EU prohlášení o shodě je k dispozici na této internetové adrese: https://europe.yamaha.com/en/support/compliance/doc.html</p>	
DA	FORENKLET EU-OVERENSSTEMMELSESERKLÆRING
<p>Hermed erklærer Yamaha Music Europe GmbH, at radioudstyrstypen [CSP-295GP, CSP-295, CSP-275, CSP-255] er i overensstemmelse med direktiv 2014/53/EU. EU-overensstemmelseserklæringens fulde tekst kan findes på følgende internetadresse: https://europe.yamaha.com/en/support/compliance/doc.html</p>	

ET LIHSTUSSTATUD ELI VASTAVUSDEKLARATSIOON

Käesolevaga deklareerib Yamaha Music Europe GmbH, et käesolev raadioseadme tüüp [CSP-295GP, CSP-295, CSP-275, CSP-255] vastab direktiivi 2014/53/EL nõuetele. ELi vastavusdeklaratsiooni täielik tekst on kättesaadav järgmisel internetiaadressil:
<https://europe.yamaha.com/en/support/compliance/doc.html>

EL ΑΠΛΟΥΣΤΕΥΜΕΝΗ ΔΗΛΩΣΗ ΣΥΜΜΟΡΦΩΣΗΣ ΕΕ

Με την παρούσα ο/η Yamaha Music Europe GmbH, δηλώνει ότι ο ραδιοεξοπλισμός [CSP-295GP, CSP-295, CSP-275, CSP-255] πληροί την οδηγία 2014/53/ΕΕ. Το πλήρες κείμενο της δήλωσης συμμόρφωσης ΕΕ διατίθεται στην ακόλουθη ιστοσελίδα στο διαδίκτυο:
<https://europe.yamaha.com/en/support/compliance/doc.html>

HR POJEDNOSTAVLJENA EU IZJAVA O SUKLADNOSTI

Yamaha Music Europe GmbH ovime izjavljuje da je radijska oprema tipa [CSP-295GP, CSP-295, CSP-275, CSP-255] u skladu s Direktivom 2014/53/EU. Cjeloviti tekst EU izjave o sukladnosti dostupan je na sljedećoj internetskoj adresi:
<https://europe.yamaha.com/en/support/compliance/doc.html>

LV VIENKĀRŠOTA ES ATBILSTĪBAS DEKLARĀCIJA

Ar šo Yamaha Music Europe GmbH deklarē, ka radioiekārta [CSP-295GP, CSP-295, CSP-275, CSP-255] atbilst Direktīvai 2014/53/ES. Pilns ES atbilstības deklarācijas teksts ir pieejams šādā interneta vietnē:
<https://europe.yamaha.com/en/support/compliance/doc.html>

LT SUPAPRASTINTA ES ATITIKTIES DEKLARACIJA

Aš, Yamaha Music Europe GmbH, patvirtinu, kad radijo įrenginių tipas [CSP-295GP, CSP-295, CSP-275, CSP-255] atitinka Direktyvą 2014/53/ES. Visas ES atitikties deklaracijos tekstas prieinamas šiuo interneto adresu:
<https://europe.yamaha.com/en/support/compliance/doc.html>

HU EGSZERŰSÍTETT EU-MEGFELELŐSÉGI NYILATKOZAT

Yamaha Music Europe GmbH igazolja, hogy a [CSP-295GP, CSP-295, CSP-275, CSP-255] típusú rádióberendezés megfelel a 2014/53/EU irányelvnek. Az EU-megfelelőségi nyilatkozat teljes szövege elérhető a következő internetes címen:
<https://europe.yamaha.com/en/support/compliance/doc.html>

PL UPROSZCZONA DEKLARACJA ZGODNOŚCI UE

Yamaha Music Europe GmbH niniejszym oświadcza, że typ urządzenia radiowego [CSP-295GP, CSP-295, CSP-275, CSP-255] jest zgodny z dyrektywą 2014/53/UE. Pełny tekst deklaracji zgodności UE jest dostępny pod następującym adresem internetowym:
<https://europe.yamaha.com/en/support/compliance/doc.html>

RO DECLARAȚIA UE DE CONFORMITATE SIMPLIFICATĂ

Prin prezenta, Yamaha Music Europe GmbH declară că tipul de echipamente radio [CSP-295GP, CSP-295, CSP-275, CSP-255] este în conformitate cu Directiva 2014/53/UE. Textul integral al declarației UE de conformitate este disponibil la următoarea adresă internet:
<https://europe.yamaha.com/en/support/compliance/doc.html>

SK ZJEDNODUŠENÉ EÚ VYHLÁSENIE O ZHODE

Yamaha Music Europe GmbH týmto vyhlasuje, že rádiové zariadenie typu [CSP-295GP, CSP-295, CSP-275, CSP-255] je v súlade so smernicou 2014/53/EÚ. Úplné EÚ vyhlásenie o zhode je k dispozícii na tejto internetovej adrese:
<https://europe.yamaha.com/en/support/compliance/doc.html>

SL POENOSTAVLJENA IZJAVA EU O SKLADNOSTI

Yamaha Music Europe GmbH potrjuje, da je tip radijske opreme [CSP-295GP, CSP-295, CSP-275, CSP-255] skladen z Direktivo 2014/53/EU. Celotno besedilo izjave EU o skladnosti je na voljo na naslednjem spletnem naslovu:
<https://europe.yamaha.com/en/support/compliance/doc.html>

FI YKSINKERTAISTETTU EU-VAATIMUSTENMUKAISUUSVAKUUTUS

Yamaha Music Europe GmbH vakuuttaa, että radiolaitetyypit [CSP-295GP, CSP-295, CSP-275, CSP-255] on direktiivin 2014/53/EU mukainen. EU-vaatimustenmukaisuusvakuutuksen täysimittainen teksti on saatavilla seuraavassa internetosoitteessa:
<https://europe.yamaha.com/en/support/compliance/doc.html>

TR BASİTLEŞTİRİLMİŞ AVRUPA BİRLİĞİ UYGUNLUK BİLDİRİMİ

İşbu belge ile, Yamaha Music Europe GmbH, radyo cihaz tipinin [CSP-295GP, CSP-295, CSP-275, CSP-255], Direktif 2014/53/ AB'ye uygunluğunu beyan eder. AB uyumu beyanının tam metni aşağıdaki internet adresinden edinilebilir:
<https://europe.yamaha.com/en/support/compliance/doc.html>

Apache License 2.0

Copyright (c) 2009-2018 Arm Limited. All rights reserved.

SPDX-License-Identifier: Apache-2.0

Licensed under the Apache License, Version 2.0 (the License); you may not use this file except in compliance with the License. You may obtain a copy of the License at www.apache.org/licenses/LICENSE-2.0

Unless required by applicable law or agreed to in writing, software distributed under the License is distributed on an AS IS BASIS, WITHOUT WARRANTIES OR CONDITIONS OF ANY KIND, either express or implied. See the License for the specific language governing permissions and limitations under the License.

Modified BSD license

COPYRIGHT(c) 2016 STMicroelectronics

Redistribution and use in source and binary forms, with or without modification, are permitted provided that the following conditions are met:

1. Redistributions of source code must retain the above copyright notice, this list of conditions and the following disclaimer.
2. Redistributions in binary form must reproduce the above copyright notice, this list of conditions and the following disclaimer in the documentation and/or other materials provided with the distribution.
3. Neither the name of STMicroelectronics nor the names of its contributors may be used to endorse or promote products derived from this software without specific prior written permission.

THIS SOFTWARE IS PROVIDED BY THE COPYRIGHT HOLDERS AND CONTRIBUTORS "AS IS" AND ANY EXPRESS OR IMPLIED WARRANTIES, INCLUDING, BUT NOT LIMITED TO, THE IMPLIED WARRANTIES OF MERCHANTABILITY AND FITNESS FOR A PARTICULAR PURPOSE ARE DISCLAIMED. IN NO EVENT SHALL THE COPYRIGHT HOLDER OR CONTRIBUTORS BE LIABLE FOR ANY DIRECT, INDIRECT, INCIDENTAL, SPECIAL, EXEMPLARY, OR CONSEQUENTIAL DAMAGES (INCLUDING, BUT NOT LIMITED TO, PROCUREMENT OF SUBSTITUTE GOODS OR SERVICES; LOSS OF USE, DATA, OR PROFITS; OR BUSINESS INTERRUPTION) HOWEVER CAUSED AND ON ANY THEORY OF LIABILITY, WHETHER IN CONTRACT, STRICT LIABILITY, OR TORT (INCLUDING NEGLIGENCE OR OTHERWISE) ARISING IN ANY WAY OUT OF THE USE OF THIS SOFTWARE, EVEN IF ADVISED OF THE POSSIBILITY OF SUCH DAMAGE.



Important Notice: U.S. LIMITED WARRANTY for Customers in the United States

For detailed information about this Yamaha product and warranty service, please either visit the following website address (printable file is available at our website) or contact Customer Service at the address or telephone number identified below.

Website Address:

Yamaha.io/ClavinovaWarranty

Customer Service:

Yamaha Corporation of America
6600 Orangethorpe Avenue, Buena Park, CA 90620-1273
Telephone: 800-854-1569

Important Notice: Guarantee Information for customers in European Economic Area (EEA) and Switzerland

<p>Important Notice: Guarantee Information for customers in EEA* and Switzerland</p> <p>For detailed guarantee information about this Yamaha product, and Pan-EEA* and Switzerland warranty service, please either visit the website address below (Printable file is available at our website) or contact the Yamaha representative office for your country. * EEA: European Economic Area</p>	English
<p>Wichtiger Hinweis: Garantie-Information für Kunden in der EWR* und der Schweiz</p> <p>Für nähere Garantie-Information über dieses Produkt von Yamaha, sowie über den Pan-EWR*- und Schweizer Garantieservice, besuchen Sie bitte entweder die folgend angegebene Internetadresse (eine druckfähige Version befindet sich auch auf unserer Webseite), oder wenden Sie sich an den für Ihr Land zuständigen Yamaha-Vertrieb. * EWR: Europäischer Wirtschaftsraum</p>	Deutsch
<p>Remarque importante: informations de garantie pour les clients de l'EEE et la Suisse</p> <p>Pour des informations plus détaillées sur la garantie de ce produit Yamaha et sur le service de garantie applicable dans l'ensemble de l'EEE ainsi qu'en Suisse, consultez notre site Web à l'adresse ci-dessous (Le fichier imprimable est disponible sur notre site Web) ou contactez directement Yamaha dans votre pays de résidence. * EEE : Espace Economique Européen</p>	Français
<p>Belangrijke mededeling: Garantie-informatie voor klanten in de EER* en Zwitserland</p> <p>Voor gedetailleerde garantie-informatie over dit Yamaha-product en de garantieservice in heel de EER* en Zwitserland, gaat u naar de onderstaande website (u vindt een afdrukbaar bestand op onze website) of neemt u contact op met de vertegenwoordiging van Yamaha in uw land. * EER: Europese Economische Ruimte</p>	Nederlands
<p>Aviso importante: información sobre la garantía para los clientes del EEE* y Suiza</p> <p>Para una información detallada sobre este producto Yamaha y sobre el soporte de garantía en la zona EEE* y Suiza, visite la dirección web que se incluye más abajo (la versión del archivo para imprimir esta disponible en nuestro sitio web) o póngase en contacto con el representante de Yamaha en su país. * EEE: Espacio Económico Europeo</p>	Español
<p>Avviso importante: informazioni sulla garanzia per i clienti residenti nell'EEA* e in Svizzera</p> <p>Per informazioni dettagliate sulla garanzia relativa a questo prodotto Yamaha e l'assistenza in garanzia nei paesi EEA* e in Svizzera, potete consultare il sito Web all'indirizzo riportato di seguito (è disponibile il file in formato stampabile) oppure contattare l'ufficio di rappresentanza locale della Yamaha. * EEA: Area Economica Europea</p>	Italiano
<p>Aviso importante: informações sobre as garantias para clientes da AEE* e da Suíça</p> <p>Para obter uma informação pormenorizada sobre este produto da Yamaha e o serviço de garantia na AEE* e na Suíça, visite o site a seguir (o arquivo para impressão está disponível no nosso site) ou entre em contato com o escritório de representação da Yamaha no seu país. * AEE: Área Económica Européia</p>	Português
<p>Σημαντική σημείωση: Πληροφορίες εγγύησης για τους πελάτες στον ΕΟΧ* και Ελλάδα</p> <p>Για λεπτομερείς πληροφορίες εγγύησης σχετικά με το παρόν προϊόν της Yamaha και την κάλυψη εγγύησης σε όλες τις χώρες του ΕΟΧ και την Ελλάδα, επισκεφτείτε την παρακάτω ιστοσελίδα (Εκτυπώσιμη μορφή είναι διαθέσιμη στην ιστοσελίδα μας) ή απευθυνθείτε στην αντιπροσωπεία της Yamaha στη χώρα σας. * ΕΟΧ: Ευρωπαϊκός Οικονομικός Χώρος</p>	Ελληνικά
<p>Viktigt: Garantiinformation för kunder i EES-området* och Schweiz</p> <p>För detaljerad information om denna Yamahaprodukt samt garantiservice i hela EES-området* och Schweiz kan du antingen besöka nedanstående webbadress (en utskriftsvänlig fil finns på webbplatsen) eller kontakta Yamahas officiella representant i ditt land. * EES: Europeiska Ekonomiska Samarbetsområdet</p>	Svenska
<p>Viktig merknad: Garantiinformasjon for kunder i EØS* og Sveits</p> <p>Detaljert garantiinformasjon om dette Yamaha-produktet og garantiservice for hele EØS-området* og Sveits kan fås enten ved å besøke nettstedene nedenfor (utskriftsversjon finnes på våre nettsider) eller kontakte Yamahas kontoret i landet der du bor. * EØS: Det europeiske økonomiske samarbeidsområdet</p>	Norsk
<p>Vigtig oplysning: Garantioplysninger til kunder i EØO* og Schweiz</p> <p>De kan finde detaljerede garantioplysninger om dette Yamaha-produkt og den fælles garantiserviceordning for EØO* (og Schweiz) ved at besøge det websted, der er angivet nedenfor (der findes en fil, som kan udskrives, på vores websted), eller ved at kontakte Yamahas nationale repræsentationskontor i det land, hvor De bor. * EØO: Det Europæiske Økonomiske Område</p>	Dansk
<p>Tärkeä ilmoitus: Takuutiedot Euroopan talusalueen (ETA) ja Sveitsin asiakkaille</p> <p>Tämän Yamaha-tuotteen sekä ETA-alueen ja Sveitsin takuuta koskevat yksityiskohtaiset tiedot saatte alla olevasta nettiosoitteesta. (Tulostettava tiedosto saatavissa sivustollamme.) Voitte myös ottaa yhteyttä paikalliseen Yamaha-edustajaan. *ETA: Euroopan talusalue</p>	Suomi
<p>Ważne: Warunki gwarancyjne obowiązujące w EOG* i Szwajcarii</p> <p>Aby dowiedzieć się więcej na temat warunków gwarancyjnych tego produktu firmy Yamaha i serwisu gwarancyjnego w całym EOG* i Szwajcarii, należy odwiedzić wskazaną poniżej stronę internetową (Plik gotowy do wydruku znajduje się na naszej stronie internetowej) lub skontaktować się z przedstawicielstwem firmy Yamaha w swoim kraju. * EOG — Europejski Obszar Gospodarczy</p>	Polski
<p>Důležité oznámení: Záruční informace pro zákazníky v EHS* a ve Švýcarsku</p> <p>Podrobné záruční informace o tomto produktu Yamaha a záručním servisu v celém EHS* a ve Švýcarsku naleznete na níže uvedené webové adrese (soubor k tisku je dostupný na našich webových stránkách) nebo se můžete obrátit na zastoupení firmy Yamaha ve své zemi. * EHS: Evropský hospodářský prostor</p>	Česky
<p>Fontos figyelmeztetés: Garancia-információk az EGT* területén és Svájcban élő vásárlók számára</p> <p>A jelen Yamaha termékre vonatkozó részletes garancia-információk, valamint az EGT*-re és Svájcra kiterjedő garanciális szolgáltatás tekintetében keresse fel webhelyünket az alábbi címen (a webhelyen nyomtatható fájl is talál), vagy pedig lépjen kapcsolatba az országában működő Yamaha képviselői irodával. * EGT: Európai Gazdasági Térség</p>	Magyar
<p>Oluline märkus: Garantiteave Euroopa Majanduspiirkonna (EMP)* ja Šveitsi klientidele</p> <p>Täpsema teabe saamiseks selle Yamaha toote garantii ning kogu Euroopa Majanduspiirkonna ja Šveitsi garantiiteeniduse kohta, külastage palun veebisaiti alljärgneval aadressil (meie saidil on saadaval printitav fail) või pöörduge Teie regiooni Yamaha esinduse poole. * EMP: Euroopa Majanduspiirkond</p>	Eesti keel
<p>Svarīgs paziņojums: garantijas informācija klientiem EEZ* un Šveicē</p> <p>Lai saņemtu detalizētu garantijas informāciju par šo Yamaha produktu, kā arī garantijas apkalpošanu EEZ* un Šveicē, lūdzam apmeklējiet zemāk norādīto tīmekļa vietnes adresi (tīmekļa vietnē ir pieejams drukājams fails) vai zvanieties ar jūsu valsti apkalpojošo Yamaha pārstāvniecību. * EEZ: Eiropas Ekonomikas zona</p>	Latviešu
<p>Děmesio: informacija dėl garantijos pirkėjams EEE* ir Šveicarijoje</p> <p>Jei reikia išsamios informacijos apie šį „Yamaha“ produktą ir jo techninę priežiūrą visoje EEE* ir Šveicarijoje, apsilankykite mūsų svetainėje toliau nurodytu adresu (svetainėje yra spausdintinas failas) arba kreipkitės į „Yamaha“ atstovybę savo šaliai. *EEE – Europos ekonominė erdvė</p>	Lietuvių kalba
<p>Dôležité upozornenie: Informácie o záruke pre zákazníkov v EHP* a Švajčiarsku</p> <p>Podrobné informácie o záruke týkajúce sa tohto produktu od spoločnosti Yamaha a garančnom servise v EHP* a Švajčiarsku nájdete na webovej stránke uvedenej nižšie (na našej webovej stránke je k dispozícii súbor na tlač) alebo sa obráťte na zástupcu spoločnosti Yamaha vo svojej krajine. * EHP: Európsky hospodársky priestor</p>	Slovenčina
<p>Pomembno obvestilo: Informacije o garanciji za kupce v EGP* in Švici</p> <p>Za podrobnejše informacije o tem Yamahinem izdelku ter garancijskem servisu v celotnem EGP in Švici, obiščite spletno mesto, ki je navedeno spodaj (natisljiva datoteka je na voljo na našem spletnem mestu), ali se obrnite na Yamahinega predstavnika v svoji državi. * EGP: Evropski gospodarski prostor</p>	Slovenščina
<p>Важно съобщение: Информация за гаранцията за клиенти в ЕИП* и Швейцария</p> <p>За подробна информация за гаранцията за този продукт на Yamaha и гаранционното обслужване в паневропейската зона на ЕИП* и Швейцария или посетете посочения по-долу уеб сайт (на нашия уеб сайт има файл за печат), или се свържете с представителния офис на Yamaha във вашата страна. * ЕИП: Европейско икономическо пространство</p>	Български език
<p>Notificare importantă: Informații despre garanție pentru clienții din SEE* și Elveția</p> <p>Pentru informații detaliate privind acest produs Yamaha și serviciul de garanție Pan-SEE* și Elveția, vizitați site-ul la adresa de mai jos (fișierul imprimabil este disponibil pe site-ul nostru) sau contactați biroul reprezentanței Yamaha din țara dumneavoastră. * SEE: Spațiul Economic European</p>	Limba română
<p>Važna obavijest: Informacije o jamstvu za države EGP-a i Švicarske</p> <p>Za detaljne informacije o jamstvu za ovaj Yamahin proizvod te jamstvenom servisu za cijeli EGP i Švicarsku, molimo Vas da posjetite web-stranicu navedenu u nastavku ili kontaktirate ovlaštenog Yamahinog dobavljača u svojoj zemlji. * EGP: Europski gospodarski prostor</p>	Hrvatski

<https://europe.yamaha.com/warranty/>

For details of products, please contact your nearest Yamaha representative or the authorized distributor listed below.

Pour plus de détails sur les produits, veuillez-vous adresser à Yamaha ou au distributeur le plus proche de vous figurant dans la liste suivante.

Para detalles sobre productos, contacte su tienda Yamaha más cercana o el distribuidor autorizado que se lista debajo.

NORTH AMERICA

CANADA

Yamaha Canada Music Ltd.
135 Milner Avenue, Toronto, Ontario M1S 3R1,
Canada
Tel: +1-416-298-1311

U.S.A.

Yamaha Corporation of America
6600 Orangethorpe Avenue, Buena Park,
CA 90620, U.S.A.
Tel: +1-714-522-9011

CENTRAL & SOUTH AMERICA

MEXICO

Yamaha de México, S.A. de C.V.
Av. Insurgentes Sur 1647 Piso 9, Col. San José
Insurgentes, Delegación Benito Juárez, CDMX,
C.P. 03900, México
Tel: +52-55-5804-0600

BRAZIL

Yamaha Musical do Brasil Ltda.
Praça Professor José Lannes, 40-Cjs 21 e 22,
Brooklin Paulista Novo CEP 04571-100 – São
Paulo – SP, Brazil
Tel: +55-11-3704-1377

ARGENTINA

**Yamaha Music Latin America, S.A.,
Sucursal Argentina**
Olga Cossetini 1553, Piso 4 Norte,
Madero Este-C1107CEK,
Buenos Aires, Argentina
Tel: +54-11-4119-7000

PANAMA AND OTHER LATIN AMERICAN REGIONS/CARIBBEAN REGIONS

Yamaha Music Latin America, S.A.
Edificio Torre Davivienda, Piso: 20 Avenida
Balboa, Marbella, Corregimiento de Bella Vista,
Ciudad de Panamá, Rep. de Panamá
Tel: +507-269-5311

EUROPE

THE UNITED KINGDOM/IRELAND

Yamaha Music Europe GmbH (UK)
Sherbourne Drive, Tilbrook, Milton Keynes,
MK7 8BL, U.K.
Tel: +44-1908-366700

GERMANY

Yamaha Music Europe GmbH
Siemensstrasse 22-34, 25462 Rellingen, Germany
Tel: +49-4101-303-0

SWITZERLAND/LIECHTENSTEIN

**Yamaha Music Europe GmbH, Branch
Switzerland in Thalwil**
Seestrasse 18a, 8800 Thalwil, Switzerland
Tel: +41-44-3878080

AUSTRIA/CROATIA/CZECH REPUBLIC/ HUNGARY/ROMANIA/SLOVAKIA/ SLOVENIA

Yamaha Music Europe GmbH, Branch Austria
Schleiergasse 20, 1100 Wien, Austria
Tel: +43-1-60203900

POLAND

**Yamaha Music Europe
Sp.z o.o. Oddział w Polsce**
ul. Młynarska 48, 01-171 Warszawa, Poland
Tel: +48-22-880-08-88

BULGARIA

Dinacord Bulgaria LTD.
Bul. Iskarsko Schose 7 Targowski Zentar
Ewropa 1528 Sofia, Bulgaria
Tel: +359-2-978-20-25

MALTA

Olimpus Music Ltd.
Valletta Road, Mosta MST9010, Malta
Tel: +356-2133-2093

NETHERLANDS/BELGIUM/ LUXEMBOURG

Yamaha Music Europe, Branch Benelux
Wattbaan 1 3439ML Nieuwegein,
The Netherlands
Tel: +31-347-358040

FRANCE

Yamaha Music Europe
7 rue Ambroise Croizat, Zone d'activités de
Pariest, 77183 Croissy-Beaubourg, France
Tel: +33-1-6461-4000

ITALY

Yamaha Music Europe GmbH, Branch Italy
Via Tinelli N.67/69 20855 Gerno di Lesmo (MB),
Italy
Tel: +39-039-9065-1

SPAIN/PORTUGAL

**Yamaha Music Europe GmbH Ibérica,
Sucursal en España**
Ctra. de la Coruña km. 17,200, 28231
Las Rozas de Madrid, Spain
Tel: +34-91-639-88-88

GREECE

Philippos Nakas S.A. The Music House
19th klm. Leof. Lavriou 190 02 Peania – Attiki,
Greece
Tel: +30-210-6686260

SWEDEN

**Yamaha Music Europe GmbH Germany Filial
Scandinavia**
JA Wettergrensgata 1, 400 43 Göteborg, Sweden
Tel: +46-31-89-34-00

DENMARK

**Yamaha Music Denmark,
Filial of Yamaha Music Europe GmbH, Tyskland**
Generatorvej 8C, ST. TH., 2860 Søborg, Denmark
Tel: +45-44-92-49-00

FINLAND

F-Musiikki Oy
Antaksentie 4
FI-01510 Vantaa, Finland
Tel: +358 (0)96185111

NORWAY

**Yamaha Music Europe GmbH Germany -
Norwegian Branch**
c/o Box 30053, 400 43 Göteborg, Sweden
Tel: +47-6716-7800

ICELAND

Hljóðfaerahúsid Ehf.
Sidumula 20
IS-108 Reykjavik, Iceland
Tel: +354-625-5050

CYPRUS

Nakis Music Cyprus Ltd.
Nikis Ave 2k
1086 Nicosia
Tel: +357-22-511080
Major Music Center
21 Ali Riza Ave. Ortakoy
P.O.Box 475 Lefkoşa, Cyprus
Tel: (392) 227 9213

RUSSIA

Yamaha Music (Russia) LLC.
Room 37, entrance 7, bld. 7, Kievskaya street,
Moscow, 121059, Russia
Tel: +7-495-626-5005

OTHER EUROPEAN REGIONS

Yamaha Music Europe GmbH
Siemensstrasse 22-34, 25462 Rellingen, Germany
Tel: +49-4101-303-0

AFRICA

Yamaha Music Gulf FZE
JAFZA-16, Office 512, P.O.Box 17328,
Jebel Ali FZE, Dubai, UAE
Tel: +971-4-801-1500

MIDDLE EAST

TURKEY

Dore Muzik
Yeni Sülün Sokak No. 10
Levent Istanbul / Turkiye
Tel: +90-212-236-3640
Fax: +90-212-259-5567

ISRAEL

RBX International Co., Ltd.
P.O.Box 10245, Petach-Tikva, 49002
Tel: (972) 3-925-6900

OTHER REGIONS

Yamaha Music Gulf FZE
JAFZA-16, Office 512, P.O.Box 17328,
Jebel Ali FZE, Dubai, UAE
Tel: +971-4-801-1500

ASIA

THE PEOPLE'S REPUBLIC OF CHINA

Yamaha Music & Electronics (China) Co., Ltd.
2F, Yunhedasha, 1818 Xinzha-lu, Jingan-qu,
Shanghai, China
Tel: +86-400-051-7700

HONG KONG

Tom Lee Music Co., Ltd.
11/F., Silvercord Tower 1, 30 Canton Road,
Tsimshatsui, Kowloon, Hong Kong
Tel: +852-2737-7688

INDIA

Yamaha Music India Private Limited
P-401, JMD Megapolis, Sector-48, Sohna Road,
Gurugram-122018, Haryana, India
Tel: +91-124-485-3300

INDONESIA

PT Yamaha Musik Indonesia Distributor
Yamaha Music Center Bldg. Jalan Jend. Gatot
Subroto Kav. 4, Jakarta 12930, Indonesia
Tel: +62-21-520-2577

KOREA

Yamaha Music Korea Ltd.
11F, Prudential Tower, 298, Gangnam-daero,
Gangnam-gu, Seoul, 06253, Korea
Tel: +82-2-3467-3300

MALAYSIA

Yamaha Music (Malaysia) Sdn. Bhd.
No.8, Jalan Perbandaran, Kelana Jaya, 47301
Petaling Jaya, Selangor, Malaysia
Tel: +60-3-78030900

SINGAPORE

Yamaha Music (Asia) Private Limited
Block 202 Hougang Street 21, #02-00,
Singapore 530202, Singapore
Tel: +65-6740-9200

TAIWAN

Yamaha Music & Electronics Taiwan Co., Ltd.
2F., No. 1, Yuanfong Rd., Banqiao Dist.,
New Taipei City 22063, Taiwan (R.O.C.)
Tel: +886-2-7741-8888

THAILAND

Siam Music Yamaha Co., Ltd.
3, 4, 15, 16th Fl., Siam Motors Building,
891/1 Rama 1 Road, Wangmai,
Pathumwan, Bangkok 10330, Thailand
Tel: +66-2215-2622

VIETNAM

Yamaha Music Vietnam Company Limited
15th Floor, Nam A Bank Tower, 201-203 Cach
Mang Thang Tam St., Ward 4, Dist.3,
Ho Chi Minh City, Vietnam
Tel: +84-28-3818-1122

OTHER ASIAN REGIONS

<https://asia.yamaha.com/>

OCEANIA

AUSTRALIA

Yamaha Music Australia Pty. Ltd.
Level 1, 80 Market Street, South Melbourne,
VIC 3205 Australia
Tel: +61-3-9693-5111

NEW ZEALAND

Music Works LTD
P.O.BOX 6246 Wellesley, Auckland 4680,
New Zealand
Tel: +64-9-634-0099

REGIONS AND TRUST TERRITORIES IN PACIFIC OCEAN

<https://asia.yamaha.com/>

Yamaha Global Site
<https://www.yamaha.com/>
Yamaha Downloads
<https://download.yamaha.com/>

© 2023 Yamaha Corporation
Published 03/2023
MWMA-B0



VFV2400